

KYOCERA  
AUTOMATIC PAPER FEEDER

**PF-1**

**SERVICE AND  
MAINTENANCE  
MANUAL**

Revision 1.0

KYOCERA CORPORATION

## NOTICE

The information in this manual is subject to change without notification. Additional pages may be inserted in future editions. The user is asked to excuse any omissions or errors in the present edition. No responsibility is assumed if accidents occur while the user is following the instructions in this manual. No responsibility is assumed for defects in the feeder's firmware.

The contents of this manual are protected by copyright. No part of this manual may be reproduced or copied by any means without the permission of the copyright holder.

©1989 by *Kyocera Corporation*

# **PREFACE**

## **Scope**

This manual contains the theory of operation for the Feeder, and is primarily intended for service technicians working in the field or repair centers. In addition, the manual can also be used as a reference document for technical personnel requiring knowledge of this feeder.

The contents of this manual have been compiled as simple and clear as possible. However, users of this manual should be acquainted with computer hardware.

## **About the Manual**

This manual is divided into six chapters. They are:

### **CHAPTER 1. GENERAL INFORMATION**

Provides general information on the PF-1 such as external configuration, and specifications.

### **CHAPTER 2. INSTALLATION**

Explains how to install the Feeder.

### **CHAPTER 3. THEORY OF OPERATION**

Explains the operation theory of the Feeder.

### **CHAPTER 4. MAINTENANCE**

Guides the service man on how to disassemble, replace and Adjust the Feeder.

### **CHAPTER 5. TROUBLESHOOTING**

Instructs the service man on how to detect defective parts or modules.

### **CHAPTER 6. PARTS CATALOG**

Shows breakdown pictures and the part numbers for the major components.

## Federal Communication Commission and Canadian Department of Communications Requirements

This equipment generates and uses radio frequency energy and if not installed and used properly, in strict accordance with the manufacturer's instructions, may cause interference to radio and television reception. It has been type tested and found to comply with the limit for a Class B computing device in accordance with the specifications in Subpart J of Part 15 of the rules, and Canadian Department of Communications radio interference regulation, which are designed to provide reasonable protection against such interference in a residential installations. Federal Communication Commission Requirements

There is no guarantee, however, that interference will not occur in a particular installation.

If this feeder does cause interference to radio or television reception, which can be determined by turning the feeder off and on, the user is encouraged to try to correct the interference by one or more of the following measures:

- Reorient the receiving antenna.
- Relocate the feeder or computer with respect to the receiver.
- Move the feeder or computer away from the receiver.
- Plug the feeder into a different outlet so that the feeder and receiver are on different branch circuits.
- Connect the feeder to the computer with a grounded, shielded interface cable.

If necessary, consult an experienced radio/television technician for additional suggestions.

You may find the following booklet prepared by the Federal Communications Commission helpful:

*How to Identify and Resolve Radio-TV Interference Problems*

This booklet is available from the U.S. Government Printing Office, Washington, D.C., Stock No. 004-000-00345-4.

### Warning

This equipment has been certified to comply with the limits for a Class B computer peripheral device, pursuant to Subpart J of Part 15 of FCC Rules. Only computing devices certified to comply with Class B limits may be attached to this equipment. Operation with non-certified equipment is likely to result in interference to radio and TV reception.

## Precautions for Servicing

The precautions listed below should always be observed when performing repair/maintenance procedures:

- Only qualified persons should perform the service on the feeder. They should be familiar with fundamental safety measures as dictated for all electronics technicians in their work line.
- Before conducting any maintenance or repair, power from both the power source and the associated peripheral devices should be disconnected.
- The feeder should not be connected to a power source until the instruction is given for doing so when conducting the test directed in this manual. When connecting the power cord to a power source, exercise extreme caution in handling the power supply or any other electronic parts which may give an electric shock.
- Check that the power source voltage conforms to the rated power voltage. Otherwise, do not use the power source for servicing it.
- To avoid damaging to fragile circuitries, use of anti-static (discharging) tools (anti-static wrist straps for instance) are strongly recommended when working with the circuitries.
- Replace components with the manufacturer's recommended components to avoid damaging the feeder. Such damage caused by use of non-approved components will void the warranty.

## Precautionary Notations

Notes, Cautions, Warnings used in this manual are classified as follows:

<b>NOTE</b>	Indicates important information.
<b>CAUTION</b>	Indicates when equipment may be damaged if procedures are ignored.
<b>WARNING</b>	Indicates when serious or fatal personal injury may occur if procedures are ignored.

**CHAPTER**  
**1**  
**GENERAL INFORMATION**

---

**TABLE OF CONTENTS**

<b>Section</b>	<b>Title</b>	<b>Page</b>
1-1	INTRODUCTION .....	1-1
1-2	PARTS IDENTIFICATION .....	1-1
1-2-1	External View .....	1-1
1-2-2	Internal View .....	1-2
1-3	SPECIFICATIONS .....	1-3

## 1-1. INTRODUCTION

The PF-1 emulates the printer's paper cassette and provides a supply of 1,000 sheets of paper (75 g/m<sup>2</sup> or 20 lbs.) for all Kyocera laser printers except the F-1010. It is shipped with a pedestal that provides mounting for the printer. The cassette simulator of the PF-1 is inserted into the standard paper cassette slot of the Printer. Once the unit is installed, the only normal operating procedure required is to load paper; operation of the unit is automatic.

During operation, the Feeder essentially functions as follows: Upon power-up and sensing that the paper cover is closed, the Feeder raises the paper elevator and feeds a sheet into the cassette simulator section. That sheet remains in the "pre-feed" position until the Printer pulls it from the cassette simulator for printing (as it would from the standard paper source). When the Feeder senses the trailing edge of the sheet, the Feeder feeds the next sheet into the cassette simulator in accordance with the timing requirements of the Printer. This process continues for all sheets fed into the Printer. As sheets are fed from the stack, the Feeder periodically raises the elevator to maintain proper contact with the feed rollers and paper corner strippers.

When the paper supply is exhausted, the Feeder will attempt a feed, but no sheet will reach the Feeder's paper path sensor and a paper out condition is assumed by the Feeder. The Feeder must be refilled and operation must be restarted at the Printer in accordance with the Printer requirements.

## 1-2. PARTS IDENTIFICATION

### 1-2-1. External View

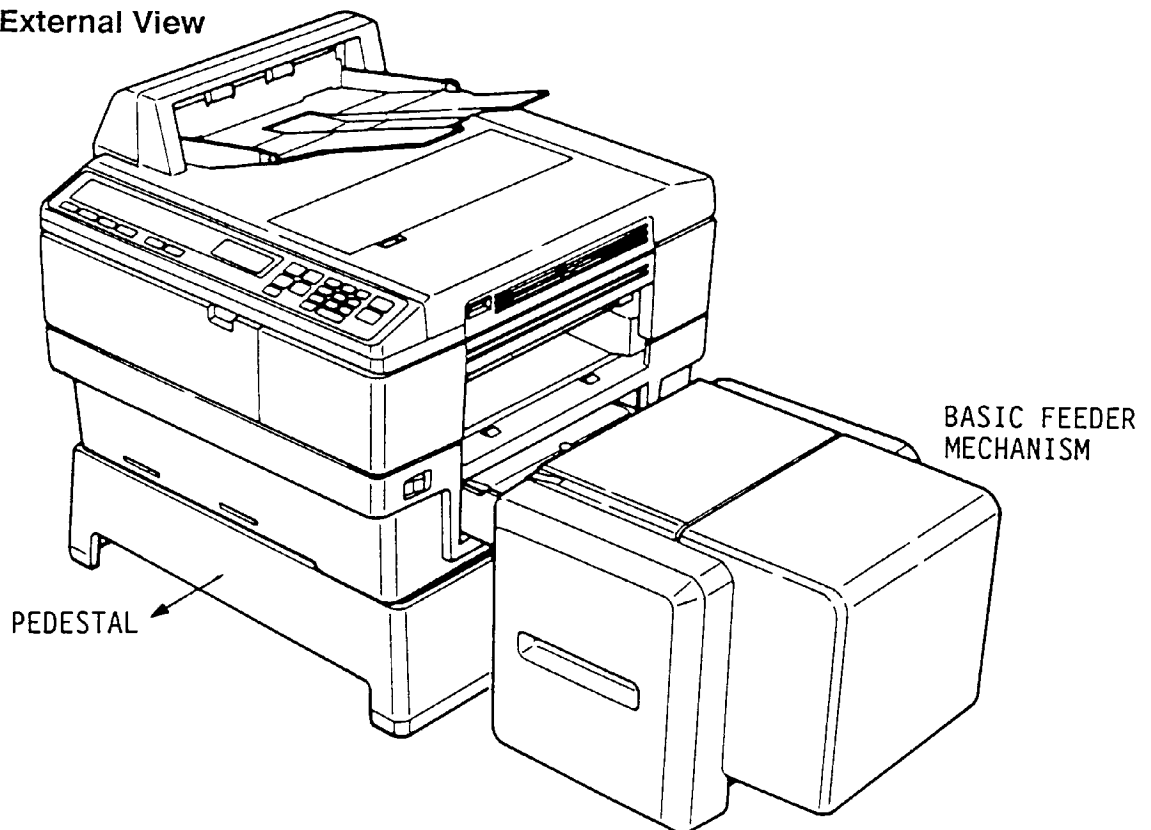

FIGURE 1-1. EXTERNAL VIEW

1-2-2. Internal View

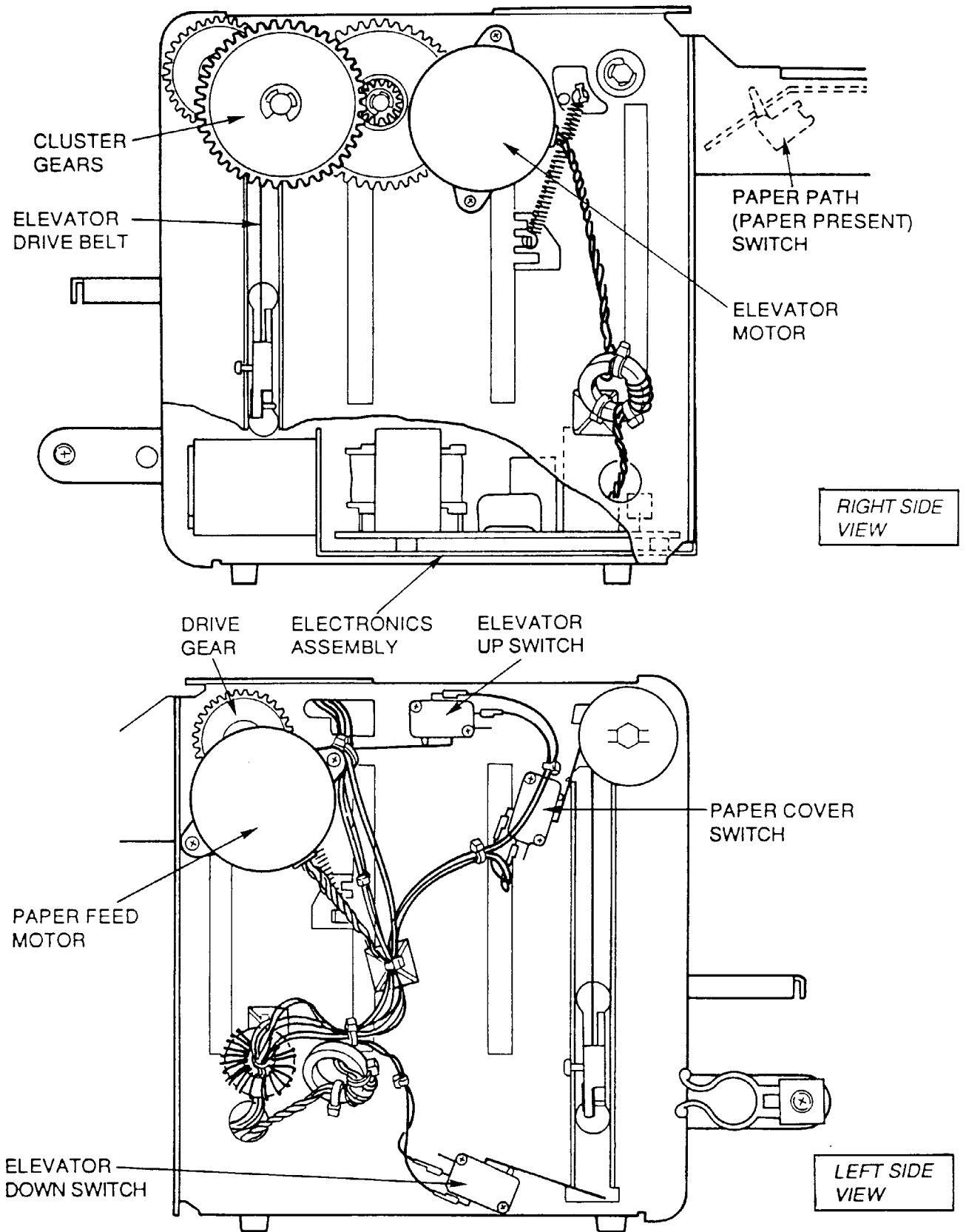

FIGURE 1-2. INTERNAL VIEW



### 1-3. SPECIFICATIONS

Applicable Printer	One paper cassette models: F-1000, F-1000A, F-1200, P-2000, and Q-8010 Two paper cassette models: F-2010, F-2200, F-2200S, F-3000 and F3010.
Paper Capacity	1000 sheets maximum, 60 to 75 g/m <sup>2</sup> (16 to 20 lbs.) paper 850 sheets maximum, 90 g/m <sup>2</sup> (24 lbs.) paper
Paper Sizes	A4: 29.7 x 21.0 cm (11.7 x 8.3 inches, European model only) Letter: 27.9 x 21.6 cm (11.0 x 8.5 inches, U.S. models only) Legal: 35.6 x 21.6 cm (14.0 x 8.5 inches, U.S. models only, Legal kit is required)
Paper Requirements	Weight: 60 to 90 g/m <sup>2</sup> (16 to 24 lbs.) Smoothness: 90 to 250 Sheffield Rag content: 20% max. Cutting Tolerance: ±0.8 mm (11/32 inches) Direction of grain: Long grain; parallel to length Operational test all other paper

#### NOTE

The Feeder is intended primarily for use with high quality copier bond paper. Other types of paper may be used; however, performance with other types of paper will vary. Textured, glossy, watermarked, embossed, perforated, cutout (punched) paper should be thoroughly tested prior to regular use, and may have to be avoided. Paper with bent edges, wrinkles, tears, etc., should be avoided. Excessive paper curl also can adversely affect feeding and printing. Paper left in the Feeder for an extended period of time may develop excessive curl. For best results, store paper on a flat surface, in a cool and dry area.

Power Requirements	100 to 120 VAC, 60Hz or 220 to 240 VAC, 50Hz
Power Consumption	35 W (maximum)
Dimensions	33 (W) x 25 (H) x 47 (D) cm 13.0 (W) x 9.8 (H) x 18.5 (D) inches
Weight	Approx. 7.2 Kg (16 lbs.), Feeder only
Option	Legal kit (for U.S. model only)
Operating Environment	Temperature: 10°C to 30°C (50°F to 86°F) Relative Humidity: 20% to 90% no condensation of moisture.

**CHAPTER**  
**2**  
**INSTALLATION**

---

**TABLE OF CONTENTS**

Section	Title	Page
2-1	INTRODUCTION .....	2-1
2-2	SITE REQUIREMENTS .....	2-1
2-2-1	Basic Requirements .....	2-1
2-2-2	Clearance .....	2-1
2-3	POWER REQUIREMENTS .....	2-2
2-3-1	Power Requirements .....	2-2
2-3-2	Not on Power .....	2-2
2-4	UNPACKING .....	2-2
2-5	SETTING UP .....	2-3
2-5-1	Pedestal .....	2-3
2-5-2	Selecting Paper Cassette .....	2-5
2-5-3	Selecting Paper Size (U.S. model only) .....	2-5
2-5-4	Feeder .....	2-6
2-5-5	Paper Capacity .....	2-6
2-5-6	Connection .....	2-6
2-6	OPERATION .....	2-7
2-6-1	Loading Paper .....	2-7
2-6-2	Refilling Paper .....	2-8
2-6-3	Special Paper .....	2-9
2-7	INSTALLING THE LEGAL KIT .....	2-10
2-7-1	Unpacking .....	2-10
2-7-2	Setting Paper Size .....	2-10
2-7-3	Installation and Connections .....	2-11

## 2-1. INTRODUCTION

This chapter describes installation and operation procedures of the Feeder. The Feeder is set up by placing the printer on the supplied pedestal, inserting the Feeder into the printer's cassette slot, and connecting the power cords. This chapter also describes installation procedure of the optional Legal kit and covers the following topics:

- Site requirements
- Power requirements
- Unpacking
- Setting up
- Operation
- Installing the Legal Kit

## 2-2. SITE REQUIREMENTS

### 2-2-1. Basic Requirements

The Feeder will work best if it is installed in a location that is:

- Level and well-supported
- Place the printer on a sturdy table or desk.
- Not exposed to sunlight or other bright light (not next to an uncurtained window)
- Normal office lighting (500 lux) is suitable.
- Near an AC wall outlet, preferably one that can be used for the Feeder (and printer) alone
- Well ventilated, not too hot or cold, and not too damp or dry
- Recommended environment

Temperature: 10°C to 30°C, ideally about 20°C  
(50°F to 90°F, ideally about 68°F)  
Humidity: 20% to 90%, ideally 65%

### 2-2-2. Clearance

For proper installation, allow at least 46 cm (18 inches) between the edge of the table and the front edge of the pedestal (see Figure 2-1). This is where the Feeder will be installed. Refer to the printer's manual for details regarding the clearance required around the printer.

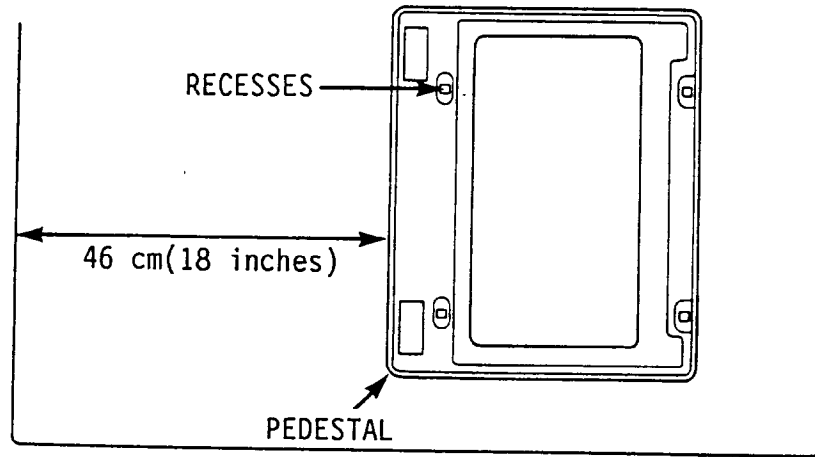

FIGURE 2-1. CLEARANCE FOR THE FEEDER

## 2-3. POWER REQUIREMENTS

### 2-3-1. Power Requirements

Voltage: 220 to 240 VAC, 50 Hz or 100 to 120 VAC, 60 Hz

Current capacity for Feeder: Max. 0.3 A at 120V; Max. 0.15 A at 220V or 240V

#### NOTE

The printer additionally requires approximately 8 A at 100 to 120 V, or 4 A at 220V/240V. Use an AC wall outlet appropriate for feeding both the Feeder and printer.

### 2-3-2. Note on Power

The Feeder runs on standard power (220 to 240 VAC, 50 Hz or 100 to 120 VAC, 60 Hz). When operating, it consumes the same amount of power as an incandescent light bulb (approximately 35W).

Because the Feeder supplies power to the printer, it should receive stable, clean power. It should not be on the same power circuit as an air conditioner, refrigerator, copier, shredder, or other noise-generating heavy-duty electrical equipment.

The outlet should have a ground slot, or you should use an adapter. If you use an extension cord, the total length of the power cord plus extension cord should be five meters (17 feet) or less.

## 2-4. UNPACKING

Check that the carton contains the following:

- PF-1 paper feeder
- Pedestal
- Power cord
- Manual
- Four rubber pads

Cut and remove all packaging tapes to unpack the Feeder, as shown in Figure 2-2 and carefully cut the elastic bands that secure the elevator by inserting scissors into the area under the paper cover, with the paper cover closed.

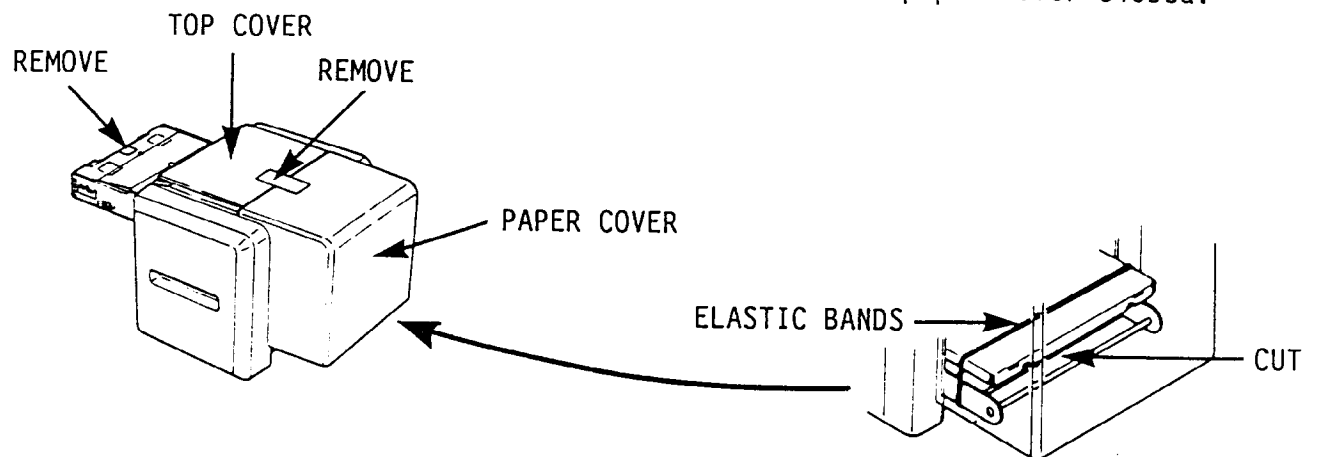

FIGURE 2-2. CUTTING THE PACKING TAPES

## 2-5. SETTING UP

### 2-5-1. Pedestal

1. For the F-1000, F-1000A, F-1200, P-2000, and Q-8010:

Position the pedestal on a sturdy table so that you can read the "THIS SIDE UP | 1BIN MODEL" indication.

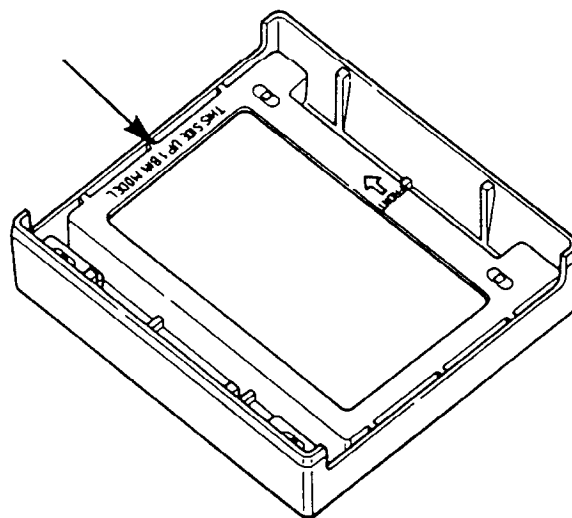

FIGURE 2-3. 1-BIN MODEL INDICATION

For the F-2010, F-2200, F-2200S, F-3000, and F-3010:

Position the pedestal on a sturdy table so that you can read the "THIS SIDE UP|2BIN MODEL" indication.

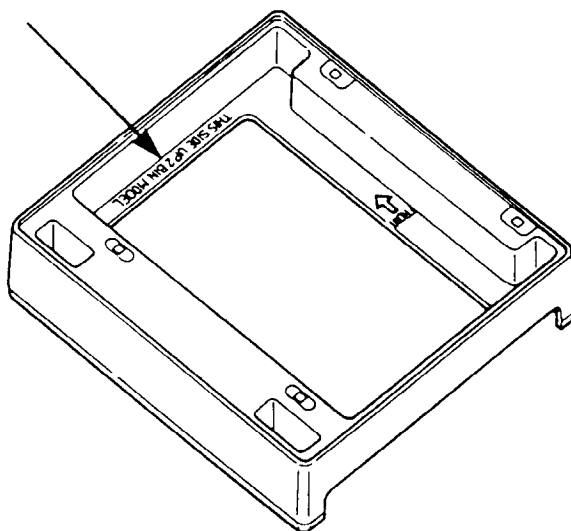

FIGURE 2-4. 2-BIN MODEL INDICATION

The front side of the pedestal is indicated by the arrow mark.

2. Place the four rubber pads on the recesses of the pedestal.
3. Switch the printer's power OFF and unplug its power cable.
4. Remove the printer's paper cassette and store it in the pedestal.
5. With the assistance of another person, place the printer atop the pedestal so that the front of the printer is flush with pedestal's front side. Ensure that the feet on the bottom of the printer fit on the rubber pads in the top of the pedestal.

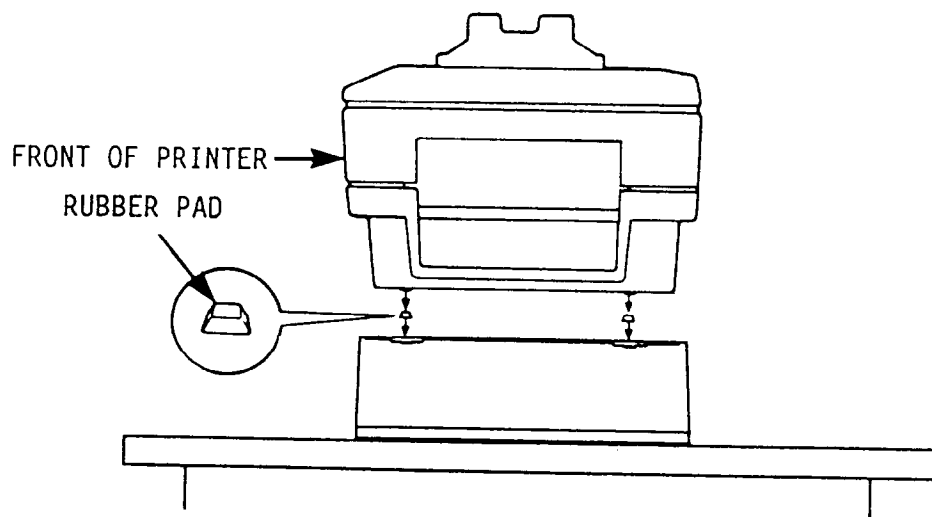
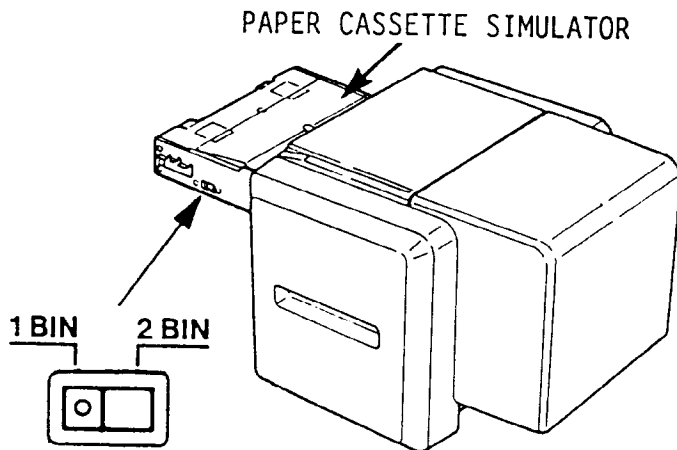

FIGURE 2-5. PLACING THE PRINTER ON THE PEDESTAL

### 2-5-2. Selecting Paper Cassette

1. Locate the cassette selector on the left side of the cassette simulator.
2. Set the switch to a suitable position for the number of your printer's paper cassette(s).



#### NOTE RESETTING THE SELECTOR SWITCH

- While the printer in use after power is fed.
  1. Switch the selector to a suitable position (1-BIN or 2-BIN), and then open and reclose the paper cover.
- Set the power off
  1. Disconnect the power cord, switch the selector to a suitable position (1-BIN or 2-BIN)

FIGURE 2-6. SETTING THE PAPER CASSETTE SELECTOR

### 2-5-3. Selecting Paper Size (U.S. model only)

1. Locate the paper size selector on the front of the cassette simulator.
2. Slide the selector to LTR (letter size) or LGL (legal size) for the paper size to be used.

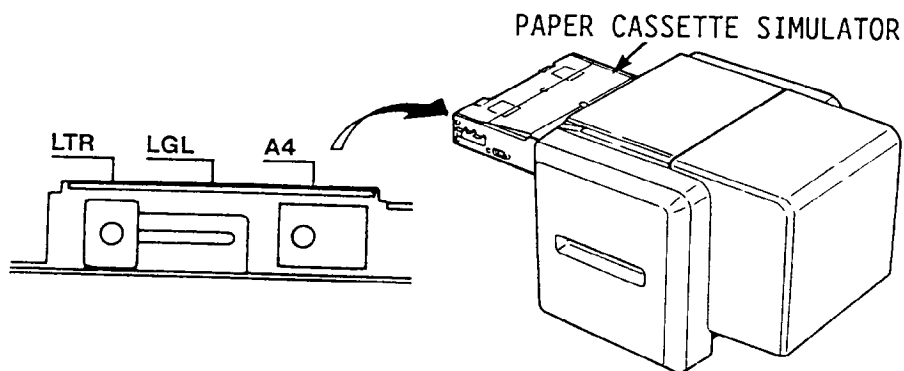

FIGURE 2-7. SETTING THE PAPER SIZE SELECTOR

#### NOTE

The paper size is factory-set to LTR (letter size). If you wish to use legal size, you need the optional legal kit; refer to Section 2-7.

#### 2-5-4. Feeder

1. Grasp the Feeder by the two handles in the side covers.
2. Align the cassette simulator of the Feeder with the paper cassette grooves in the printer.

#### CAUTION

Ensure that the Feeder is aligned correctly with the cassette grooves before proceeding.

3. Slide the Feeder into the printer ensuring that the cassette simulator slides smoothly into the slot and is seated in place.

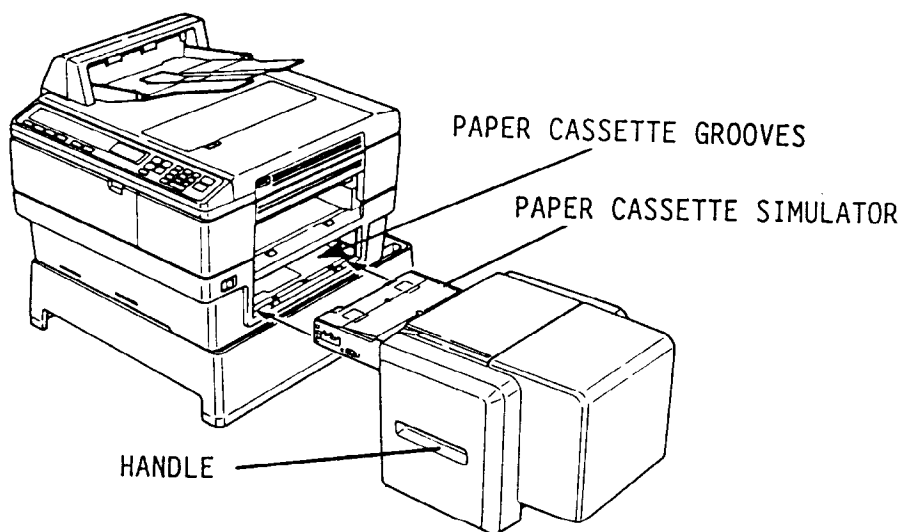

FIGURE 2-8. SLIDING THE FEEDER INTO THE PRINTER

#### 2-5-5. Paper Capacity

The Feeder's paper capacity varies depending on weight of the paper you use. The relation between the paper weight and the capacity is as shown below.

Paper weight	Capacity
60 to 75 g/m <sup>2</sup> (16 to 20 lbs.)	1000 sheets
90 g/m <sup>2</sup> (24 lbs.)	850 sheets

#### 2-5-6. Connection

1. Plug one end of the supplied power cord into the power receptacle of the Feeder, and plug the other end into the printer's power plug.
2. Plug the original printer power cord into the Feeder's power plug and the other end into the wall outlet. The Feeder is automatically turned on and the paper cassette elevator will rise (unless the paper cover is open; if necessary close the paper cover).



3. Turn on the printer.

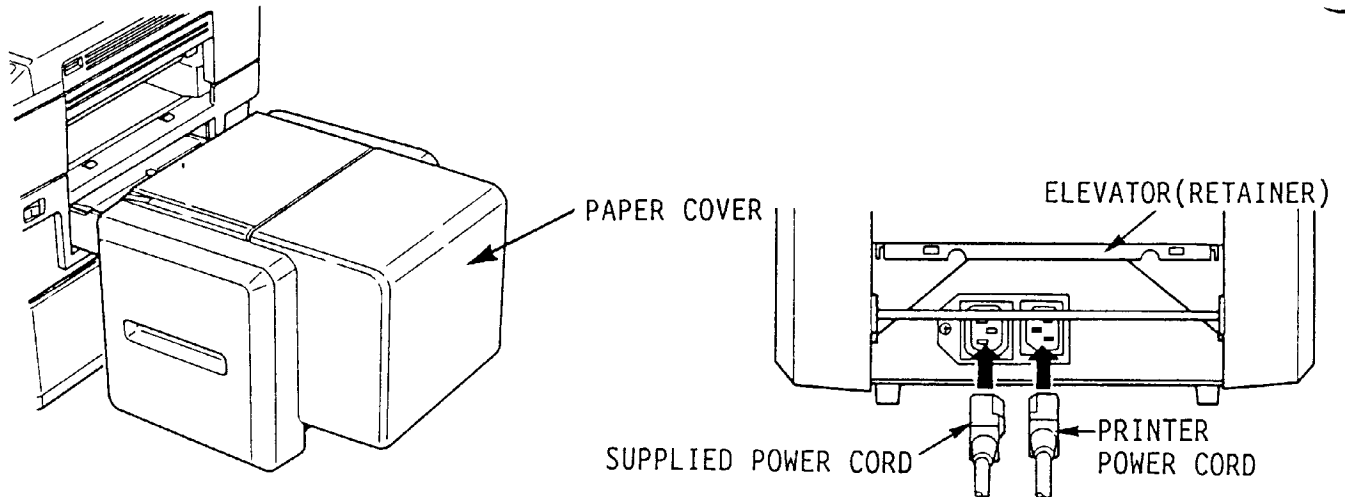

FIGURE 2-9. CONNECTING THE POWER CORDS

## 2-6. OPERATION

This section describes the normal operating procedure for the Feeder.

### 2-6-1. Loading Paper

Once the Feeder has been installed and plugged into the power source, you can prepare to load paper.

1. Gently open – pivot down – Feeder's paper cover. The elevator will lower.
2. When the elevator stops moving, load up to 1,000 sheets of paper (two standard reams or packages of 75 g/m<sup>2</sup> or 20 lbs. paper) onto the elevator. Fan and flex each ream as you load it. If you are loading a letterhead or pre-printed forms, load the paper "face-up" in the Feeder. After you load the paper, check that the paper is not contacting the feed rollers. If so, remove some paper.
3. Then close the paper cover. The elevator will rise and a sheet will feed partially into the printer. The system is ready for operation.

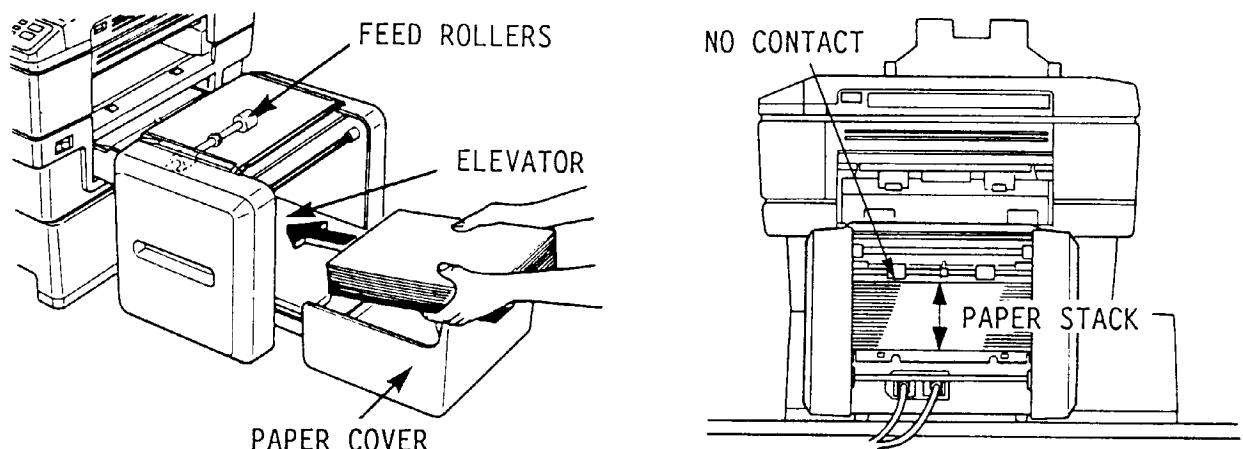

FIGURE 2-10. LOADING PAPER

## 2-6-2. Refilling Paper

Daily operation requirements consist only of reloading paper whenever it becomes necessary — normally when the Feeder completely empties. (Letting the Feeder empty prevents the last several sheets from remaining in the Feeder for extended periods of time.) When the Feeder empties and the printer tries to print, the paper indicator lights up, requiring you to reload the paper as defined below.

1. Open the paper cover.
2. When the elevator lowers, load new paper (as defined previously).
3. Then close the paper cover. The elevator raises the paper into position and feed the top sheet into the cassette simulator. The paper indicator goes off.
4. The printer will automatically go On Line and resume operation.

### CAUTION

Always let the Feeder automatically raise and lower the elevator with the opening and closing of the paper cover. Forcing the elevator up or down by hand may damage the Feeder.

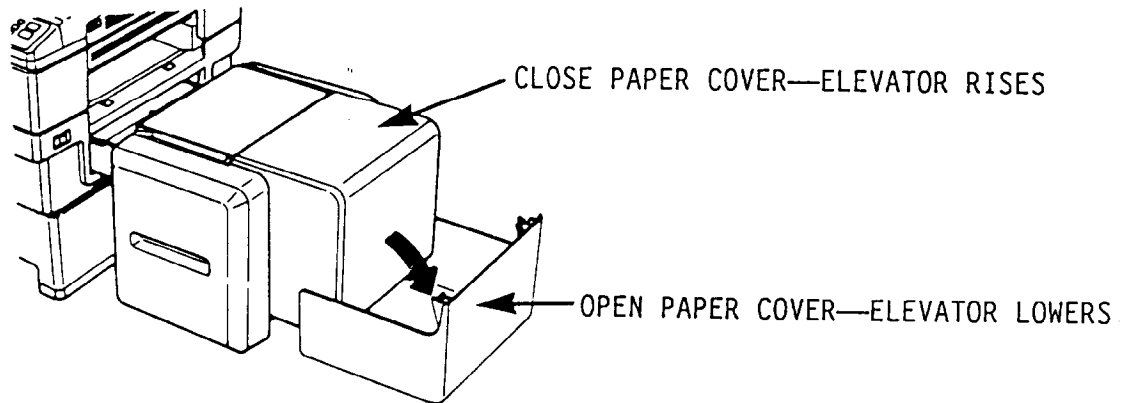

FIGURE 2-11. REFILLING PAPER

### 2-6-3. Special Paper

Sometimes you may need to feed special paper (such as a special letterhead) that is not normally loaded in the Feeder. You can leave the Feeder installed and still feed some types of special paper into the printer using the Feeder (see the Note below). To feed special paper, proceed as follows:

1. Open the paper cover; the elevator lowers.
2. Remove the sheet in the cassette simulator (at the "prefeed" position). You may have to remove some paper from the paper stack to access the sheet in the cassette simulator. The paper indicator lights up.
3. Place your special paper onto the top of the stack. If you are loading letterhead or pre-printed forms, load the paper "face-up" in the Feeder.
4. Close the paper cover to return the Feeder to automatic operation. The paper indicator goes off.
5. Check that the printer is On Line, and activate printing.

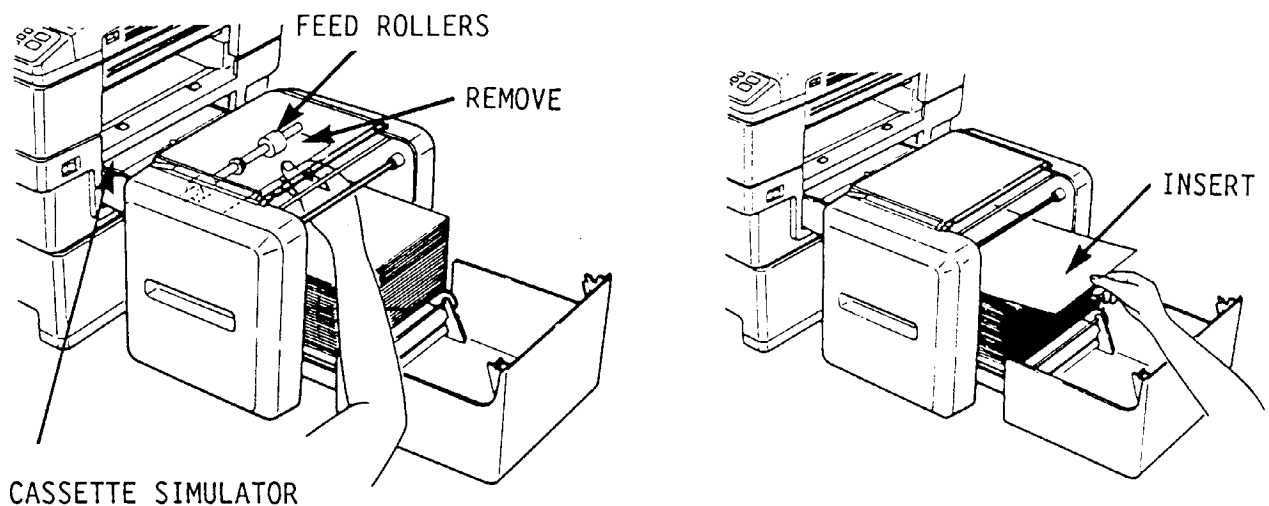

FIGURE 2-12. FEEDING SPECIAL PAPER

#### NOTE

Some types of special paper — for example, heavily embossed paper — may not feed. See Section 1-3, items "Paper requirements" and "Paper guidelines" for paper qualifications.

## 2-7. INSTALLING THE LEGAL KIT

The optional legal kit, only available for the U.S. model, enables to use legal size of 8.5 x 14 inches (21.6 x 35.6 cm) with the paper feeder by enlarging the paper elevator.

### 2-7-1. Unpacking

Check that the carton contains the following:

- Legal paper cover
- Legal paper support
- Bracket clips (2)
- Bracket extender
- Manual

Cut and remove all packing tapes to unpack the kit. Figure 2-13 shows the optional legal kit. Note the names of the parts.

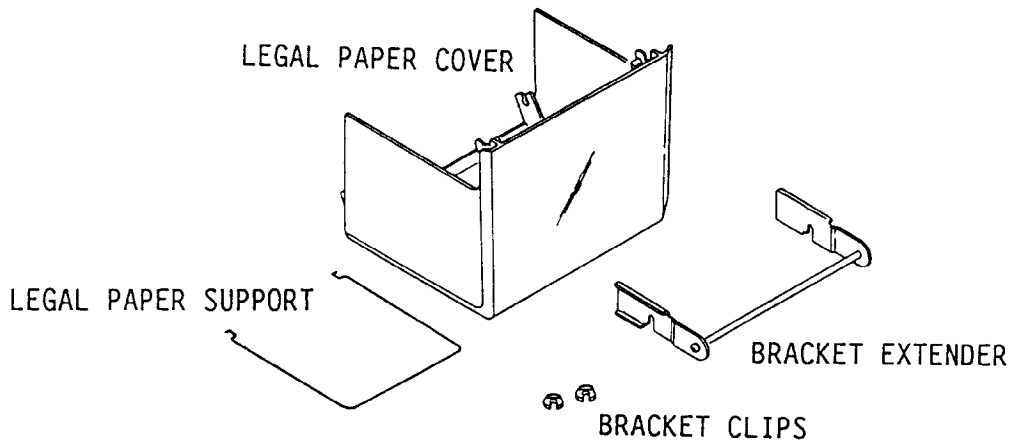

FIGURE 2-13. THE LEGAL KIT COMPONENTS

### 2-7-2. Setting Paper Size

1. Locate the paper size selector on the front of the cassette simulator.
2. Slide the paper size selector from LTR (letter size) to LGL (legal size).

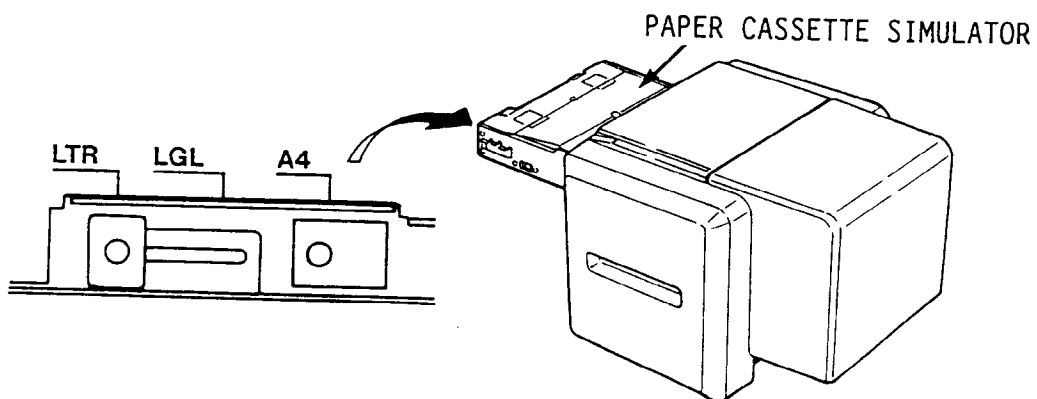

FIGURE 2-14. SETTING THE PAPER SIZE SELECTOR

### 2-7-3. Installation and Connections

#### NOTE

This procedure assumes an installed, operating system. If the Feeder has not been installed, set it on a table and use the printer's power cord to power-on the Feeder.

1. Open the paper cover and remove the paper stack.

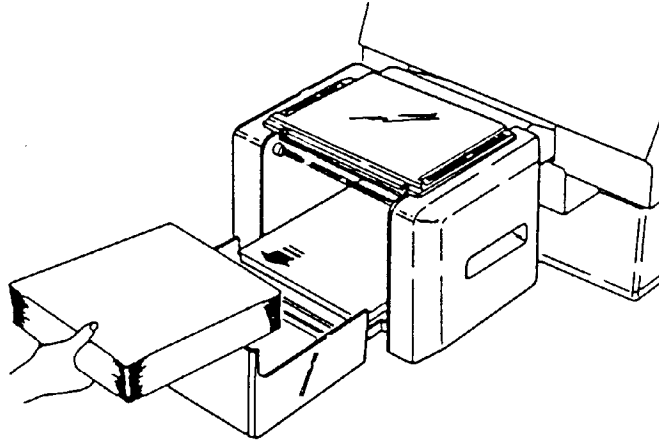

FIGURE 2-15. REMOVING THE PAPER STACK

2. Turn off the printer.
3. Close the paper cover. When the paper elevator has been raised at least halfway to the top, disconnect both AC power cords.

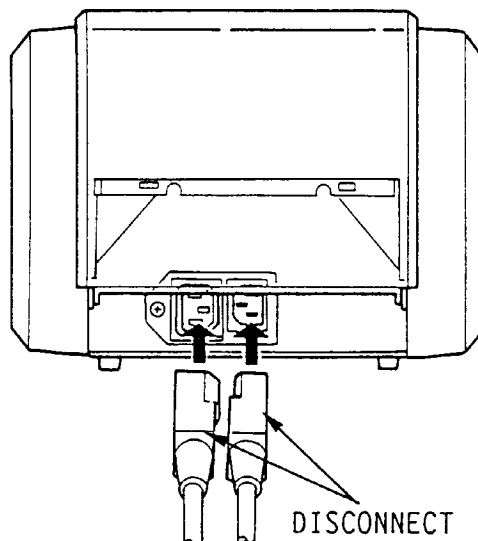

FIGURE 2-16. DISCONNECTING THE POWER CABLE

4. Gently squeeze both sides of the bottom of the paper cover, until the cover's pivot arms slide into the slots on the shaft. Then, remove the paper cover from the shaft, and store the original paper cover in a safe place.

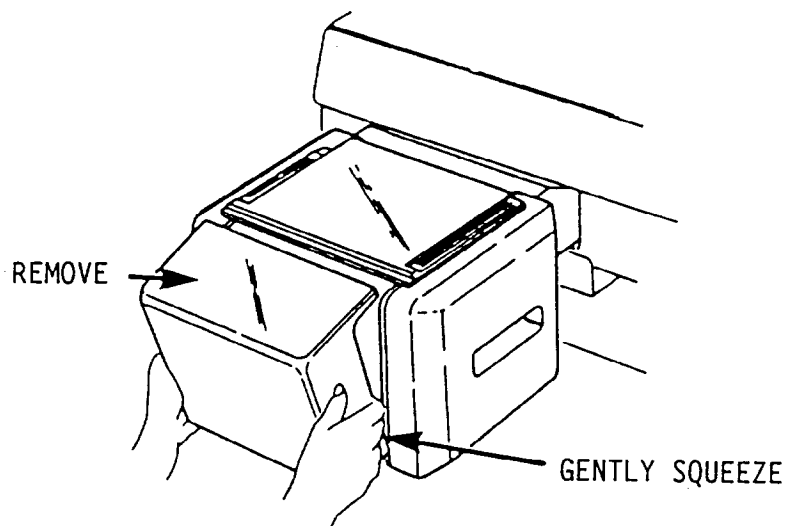

FIGURE 2-17. REMOVING THE PAPER COVER

5. Remove the Feeder from the printer and place it on the table or desk.
6. Install the supplied bracket extender into the slots on the original bracket as shown in Figure 2-18. Push the extender arms outward so that they attach to the original bracket arms.
7. Install the bracket clips onto the ends of the original shaft to secure the bracket extender in place.

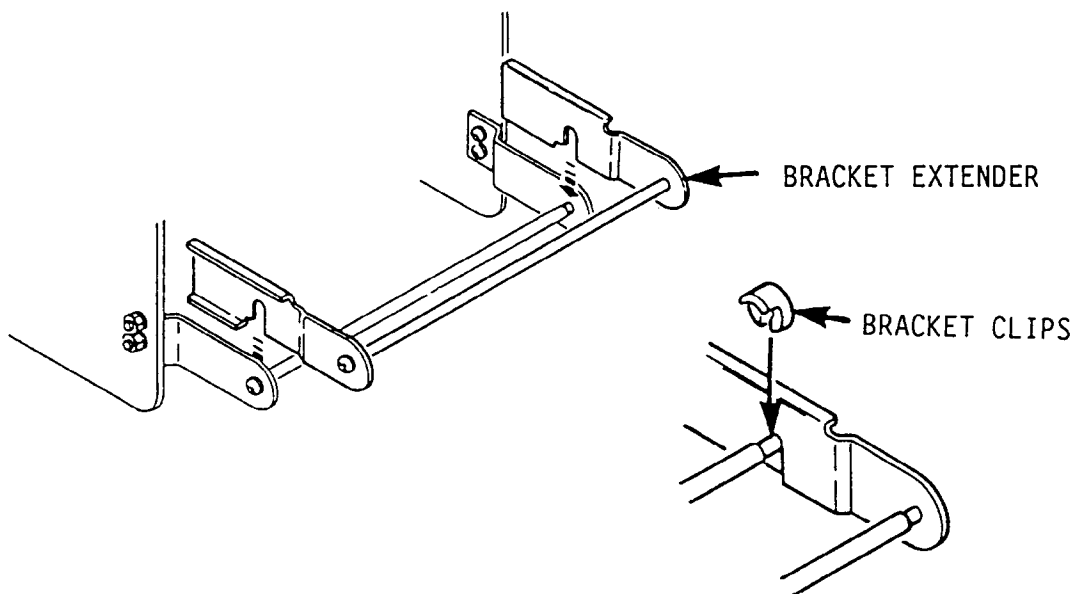

FIGURE 2-18. INSERTING THE BRACKET EXTENDER AND CLIPS

8. Slide the supplied legal paper support through the holes in the elevator, all the way into the notches in the elevator supports.

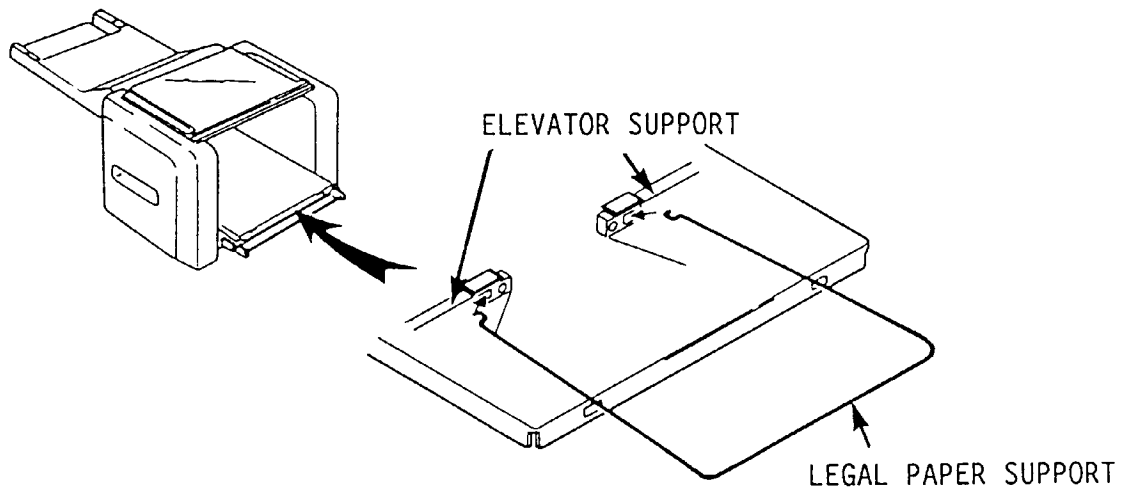

FIGURE 2-19. INSTALLING THE LEGAL PAPER SUPPORT

9. Gently squeeze the bottom of the supplied legal paper cover so that the pivot arms align with the slots on the shaft, and install the cover onto the bracket extender as shown in Figure 2-20.

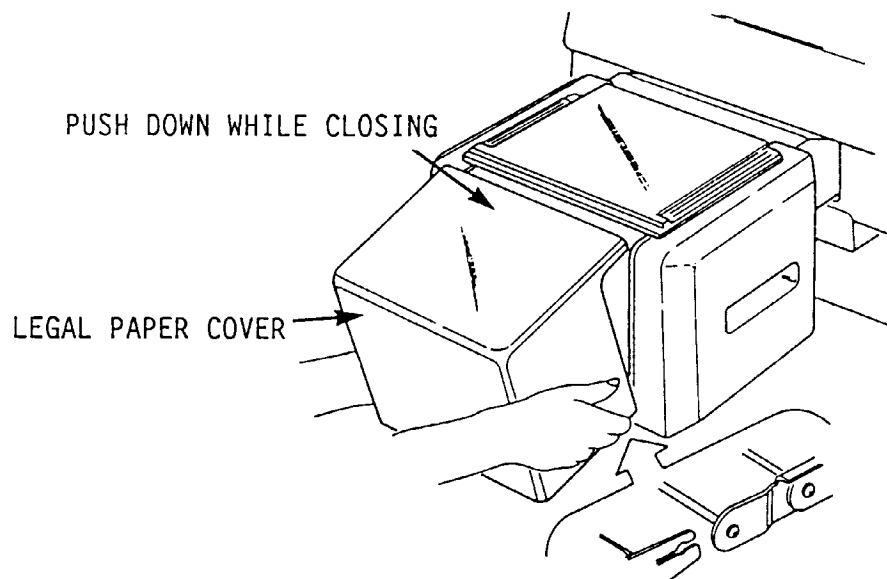

FIGURE 2-20. INSTALLING THE LEGAL PAPER COVER

10. Close the legal paper cover.
11. Slide the Feeder back into the printer.
12. Plug the original printer power cord in the Feeder's power plug and the other end into the wall outlet. The Feeder is automatically turned on and the paper cassette elevator will rise (unless the paper cover is open; if necessary close the paper cover).

13. Open the legal paper cover.

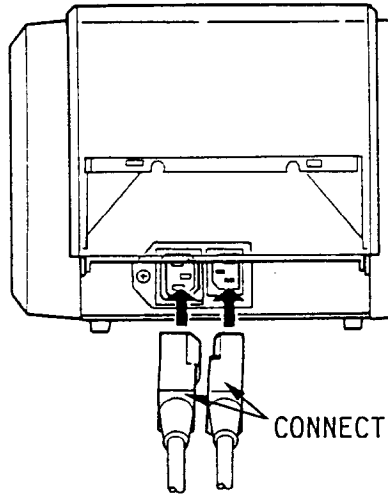

FIGURE 2-21. CONNECTING THE POWER CABLE

14. Load paper as detailed in Section 2-6-2 Loading Paper. Then, close the paper cover. While closing the legal paper cover, you should gently push down on the top of the cover to ensure that the cover latches properly.



**CHAPTER**  
**3**  
**THEORY OF OPERATION**

---

**TABLE OF CONTENTS**

<b>Section</b>	<b>Title</b>	<b>Page</b>
3-1	INTRODUCTION .....	3-1
3-2	FUNCTIONAL DESCRIPTION .....	3-1
3-3	ELECTRONIC DESCRIPTION .....	3-2
3-3-1	Main MCU .....	3-2
3-3-2	Memory and Address Circuit .....	3-3
3-3-3	Motor Drivers .....	3-3
3-3-4	Power Supply .....	3-4

### 3-1. INTRODUCTION

This section provides a theory of Feeder operation and of the electronic components and circuits utilized to control the operation. Refer to Figure 3-1 for a diagram of the electronic circuits.

### 3-2. FUNCTIONAL DESCRIPTION

Upon power-up, the Micro-Computer Unit (MCU) checks the status of the Cover switch (COVDN/). If the cover is down (open), the MCU drives the Elevator Motor such that the elevator lowers. The MCU continues to lower the elevator until the Elevator Down switch is engaged (ELDN/); the MCU then halts the Elevator Motor drive. This process permits the operator to load paper.

Once the cover is closed, the MCU drives the Elevator Motor such that the elevator raises. The MCU will raise the elevator until the Elevator Up switch is engaged by the floating paper feed roller shaft; the MCU then halts the Elevator Motor drive. This indicates that the paper stack is raised to the paper feed rollers and is ready for feeding.

#### NOTE

Once the elevator is raised to the feed position, the elevator motor detents to help hold the elevator in position. This detent action may cause the motor to emit a low volume, high pitch sound.

After the paper stack is raised, the MCU checks the Paper Path optical sensor (OPT PRES/) for the presence of paper in the cassette simulator. If no paper is present, the MCU drives the Paper Feed Motor such that a sheet is fed into the cassette simulator. The leading edge of the sheet is fed a pre-determined distance past the Paper Path sensor so that the sheet is at the pre-feed position.

The MCU continues to monitor the Paper Path sensor. Once the Printer pulls in the sheet for printing, the trailing edge of the sheet no longer interrupts the optical sensor. The MCU then activates the Paper Feed Motor to feed the next sheet into the cassette simulator.

As sheet are fed into the Printer, the paper stack is reduced. As the stack diminishes, the floating paper feed roller shaft drops, disengaging the Elevator Up switch. The MCU then drives the Elevator Motor to raise the elevator to compensate for the sheets already fed.

Essentially, the functions described above continue until the paper cover is opened, or until paper out condition is recognized by the MCU. When the paper supply is exhausted, the MCU will drive the feed rollers to feed the next sheet. The paper feed drive continues for a pre-determined time, and then, if no sheet is sensed at the Paper Path sensor, feeding halts. The Printer recognizes this as a paper out condition, and provides the standard operator feedback.

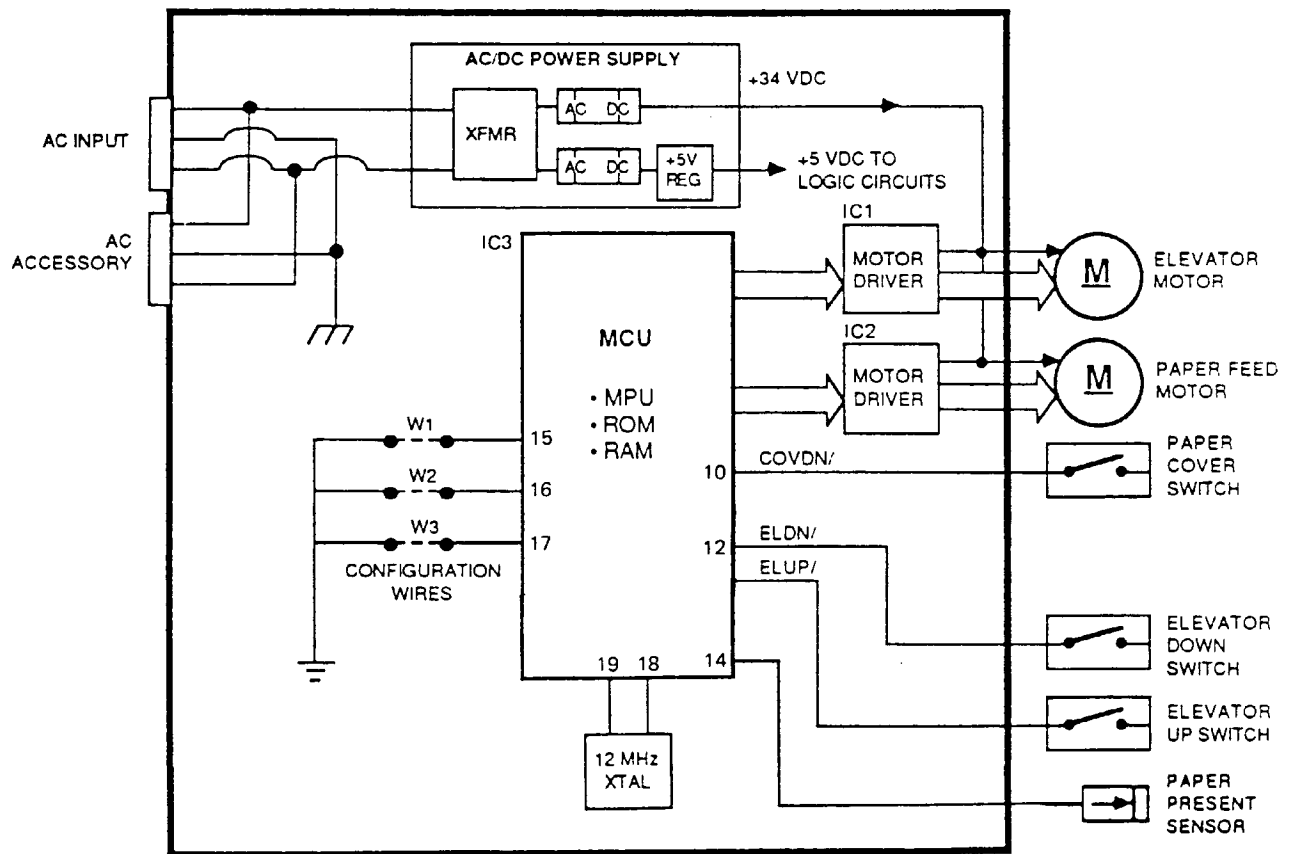

FIGURE 3-1. ELECTRONIC CIRCUITS

### 3-3. ELECTRONIC DESCRIPTION

As shown in Figure 3-1, the Feeder electronics assembly consists of a Main MCU, two motor driver circuits, and an AC/DC power supply.

#### 3-3-1. Main MCU

The Main MCU (IC3) controls all processing and I/O of the Feeder electrical components. The MCU includes 128 bytes of RAM, and 32 I/O lines.

#### NOTE

When the 8031 type MCU is used, all program memory is contained in a separate PROM circuit and is accessed via an address decode circuit (see paragraph 3-3-2). When the 8051 type MCU is used, all program memory (4K bytes) is resident in the MCU.

I/O port 1 controls the two stepper motors via the motor driver circuits (IC1 and IC2). Port 1 lines P1.0 through P1.3 activate the elevator stepper motor coils. Port 1 lines P1.4 through P1.7 activate the paper feed stepper motor coils. As both motor drive circuits are held selected, motor selection is accomplished by the MCU via appropriate P1 lines.

I/O port 3 is used to read the various switches and the configuration wires. The four switches utilized to monitor the cover, paper path, and elevator-up/down are tied to pull-up resistors. Additionally, a register-capacitor circuit provides switch debounce.

Specifically, the MCU port 3 switch connections are as follows:

- P3.0 – COVDN/ (paper cover open)
- P3.1 – PRES/ (not used)
- P3.2 – ELDN/ (elevator down)
- P3.3 – ELUP/ (elevator up)
- P3.4 – OPT PRES/ (paper in cassette simulator – optical sensor)

MCU P3.5 through P3.7 lines are connected to configuration wires W1 through W3 respectively. These are factory configurable jumper wires utilized to define proper Printer/MCU operation.

On the 8031 type MCU, I/O ports P0 and P2 access the external PROM. P0.0 through P0.7 provides address bits A0 through A7 and provide the input lines for PROM data bits D0 through D7. P2.0 through P2.3 provide the remainder of the address bits (A8 through A11).

### **3-3-2. Memory and Address Circuit**

This section applies when the 8031 type MCU is used, and is not applicable when the 8051 type MCU is used. The PROM circuit (IC4) provides 4K x 8-bit of program memory. The address decode circuit (IC5) latches the lower address bits (A0 – A7). This circuit allows MCU port 0 to both address the PROM (via IC5) and to read in the PROM contents. The MCU ALE line (pin 29) latches the address bits into IC5; the MCU PSEN/ line enables the output of the PROM (IC4) via the OE line (pin 20). The higher address bits (A8 – A11) are provided directly to the PROM by MCU port 2.

### **3-3-3. Motor Drivers**

Two identical motor driver circuits (IC1 and IC2) control the elevator and paper feed motors. The motor drivers are Darlington arrays. The MCU's individual P1 lines correspond to the four coils of each motors. MCU lines P1.0 through P1.3 control the inputs to IC1. The IC1 outputs activate the coils of the elevator stepper motor. MCU lines P1.4 through P1.7 control the inputs to IC2. The IC2 outputs activate the coils of the paper feed stepper motor.

The +34 VDC operating voltage is provided to each of 2 sets of coils for each motor via 75 ohm resistors that provide current limiting. The "diode common" lines of the motor drivers are tied to the +34 VDC return line to aid in discharging motor voltage. Capacitors provide noise filtering for the motor driver lines.

### 3-3-4. Power Supply

The power supply converts the AC input voltage to the required +5 VDC and +34 VDC. The major AC/DC supply components are contained on the circuit board. External to the circuit board are the AC input connector and the AC jumper connector. These connectors are directly wired together. As the Feeder is supplied with a "jumper" AC line cord, power from the AC power source is provided to the Feeder using the original Printer AC line cord. The "jumper" AC line cord provides power from the Feeder's accessory connector to the Printer. Two power supplies are used: one for 115 VAC operation and one for 230 VAC operation.

The AC input to the transformer is protected by a suitable input fuse (1.0 Amp, 250V for 115 VAC and 0.5 Amp, 250V for 230 VAC). The appropriate transformer (for 115VAC or 230 VAC) provides secondary AC to dual, full-wave bridge rectifiers. The output of the first rectifier circuit provides unregulated +34 VDC for the motors. A PTC provides additional input protection to the bridge rectifier for the motor voltage. The output of the second rectifier circuit is provided to the +5 volt regulator circuit. This circuit provides the regulated +5 VDC for the logic circuits. Filtering circuitry is provided by additional capacitors.

**CHAPTER**  
**4**  
**MAINTENANCE**

---

**TABLE OF CONTENTS**

Section	Title	Page
4-1	GENERAL .....	4-1
4-2	DISASSEMBLY .....	4-1
4-2-1	Side Covers .....	4-2
4-2-2	Paper Cover .....	4-3
4-2-3	Top Cover .....	4-4
4-2-4	Electronics Assembly .....	4-5
4-2-5	Circuit Board .....	4-7
4-2-6	Fuse .....	4-8
4-2-7	Elevator Motor .....	4-9
4-2-8	Paper Feed Motor .....	4-10
4-2-9	Left Side Switches .....	4-11
4-2-10	Paper Path Sensor .....	4-12
4-2-11	Paper Roller Drive Shaft .....	4-13
4-3	ADJUSTMENT .....	4-14
4-3-1	Corner Stripper Adjustment .....	4-14
4-3-2	Elevator Drive Belt Adjustment .....	4-15
4-3-3	Drive Roller Shaft Spring Adjustment .....	4-16

## 4-1. GENERAL

The main topics covered in this chapter are:

- Disassembly procedures
- Replacement procedures
- Adjustment procedures

Unless noted, be sure to turn the power switch off and to unplug the AC cord from the outlet before the maintenance.

### CAUTION

- Use a screwdriver whose tip fits the head of the screws, or you may damage the head.
- The self-tapping screws, if loosened and tightened too often, with an excessive torque, may irrevocably damage the screw hole in the unit.

## 4-2. DISASSEMBLY

In all illustrations, the callout number refers to the step number. In some cases, all steps may not be pictorially represented; therefore, the corresponding number will be omitted from the illustration. In all sections, left and right side-frame references are with respect to the front view (regardless of view shown).

In the following sections, the sentence "Remove Feeder from Printer." refers to the following procedure:

1. Remove all paper from the Feeder.
2. Turn off the Printer.
3. Disconnect both power cords.
4. Remove the Feeder from the Printer.
5. Place the Feeder on a suitable work surface.

#### 4-2-1. Side Covers

##### Removal Procedure:

1. Open paper cover (see Figure 4-1).
2. Remove paper stack.
3. Remove 2 screws that secure left/right side cover, and remove side cover.

##### Replacement Procedure:

Same as above in reverse order.

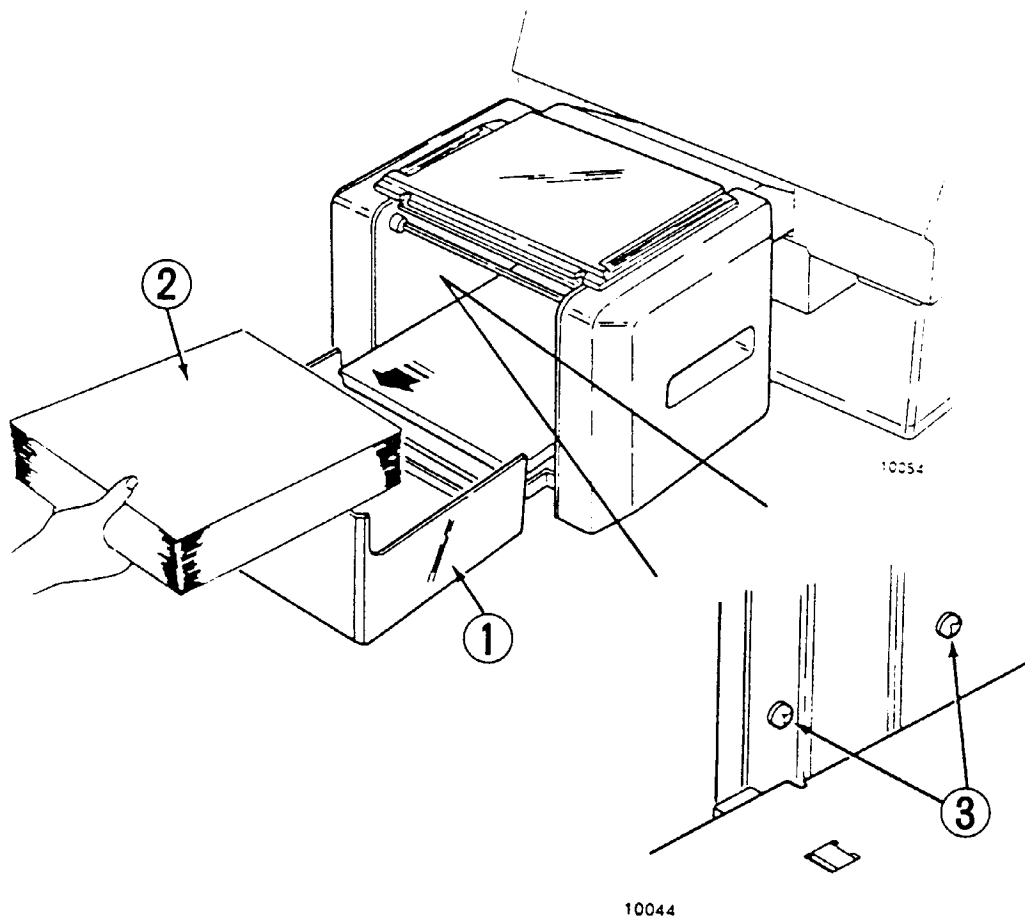

FIGURE 4-1. SIDE COVER REMOVAL



#### 4-2-2. Paper Cover

##### Removal Procedure:

1. Open paper cover slightly (see Figure 4-2).
2. Squeeze the paper cover near the pivot point until the pivot arms slide into the grooves in the shaft; then, gently pull the cover from its mounting shaft.

##### Replacement Procedure:

Same as above in reverse order.

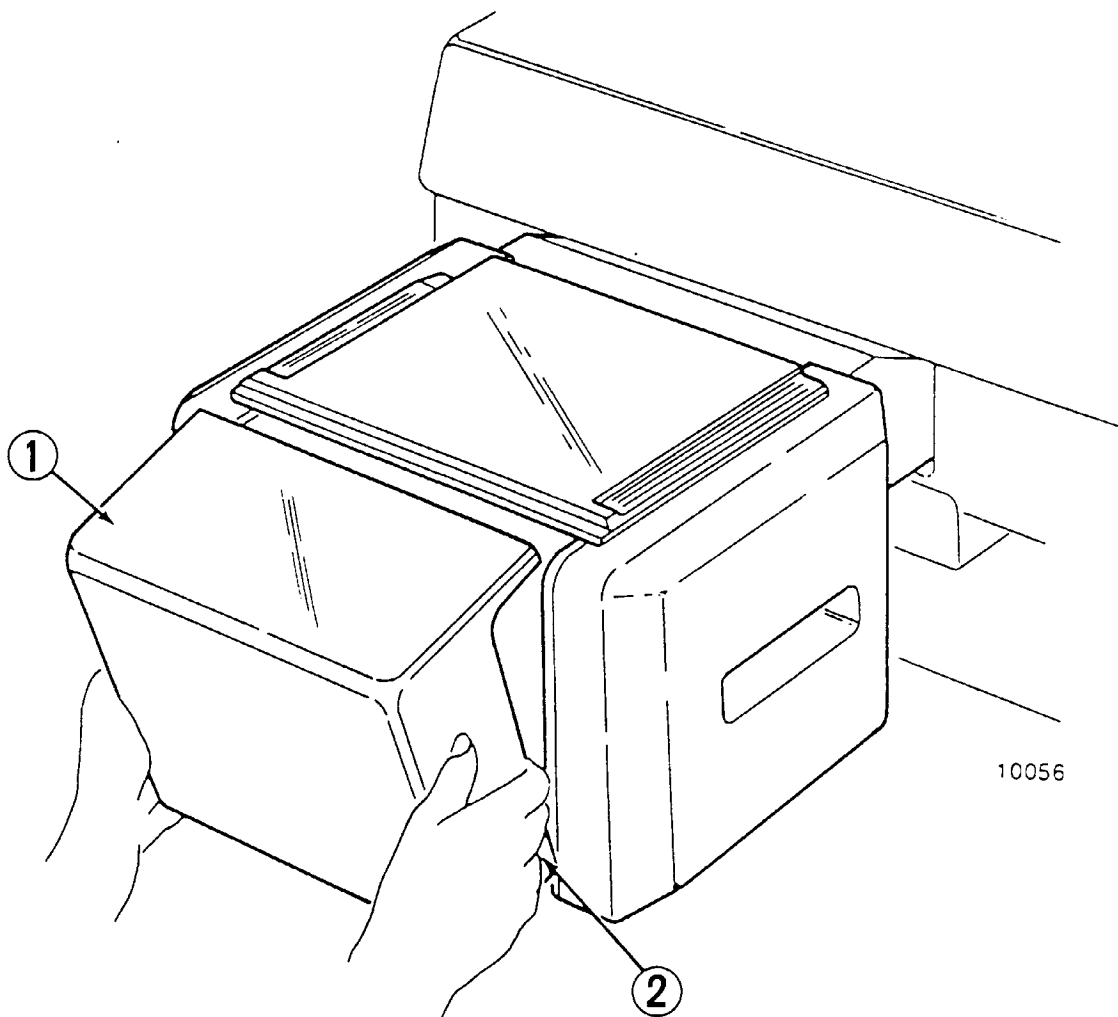

FIGURE 4-2. PAPER COVER REMOVAL

### 4-2-3. Top Cover

#### Removal Procedure:

1. Open paper cover (see Figure 4-3).
2. Remove paper stack.
3. Remove two nuts that secure top cover and remove top cover.

#### Replacement Procedure:

Same as above in reverse order.

#### CAUTION

Be careful not to overtighten nuts.

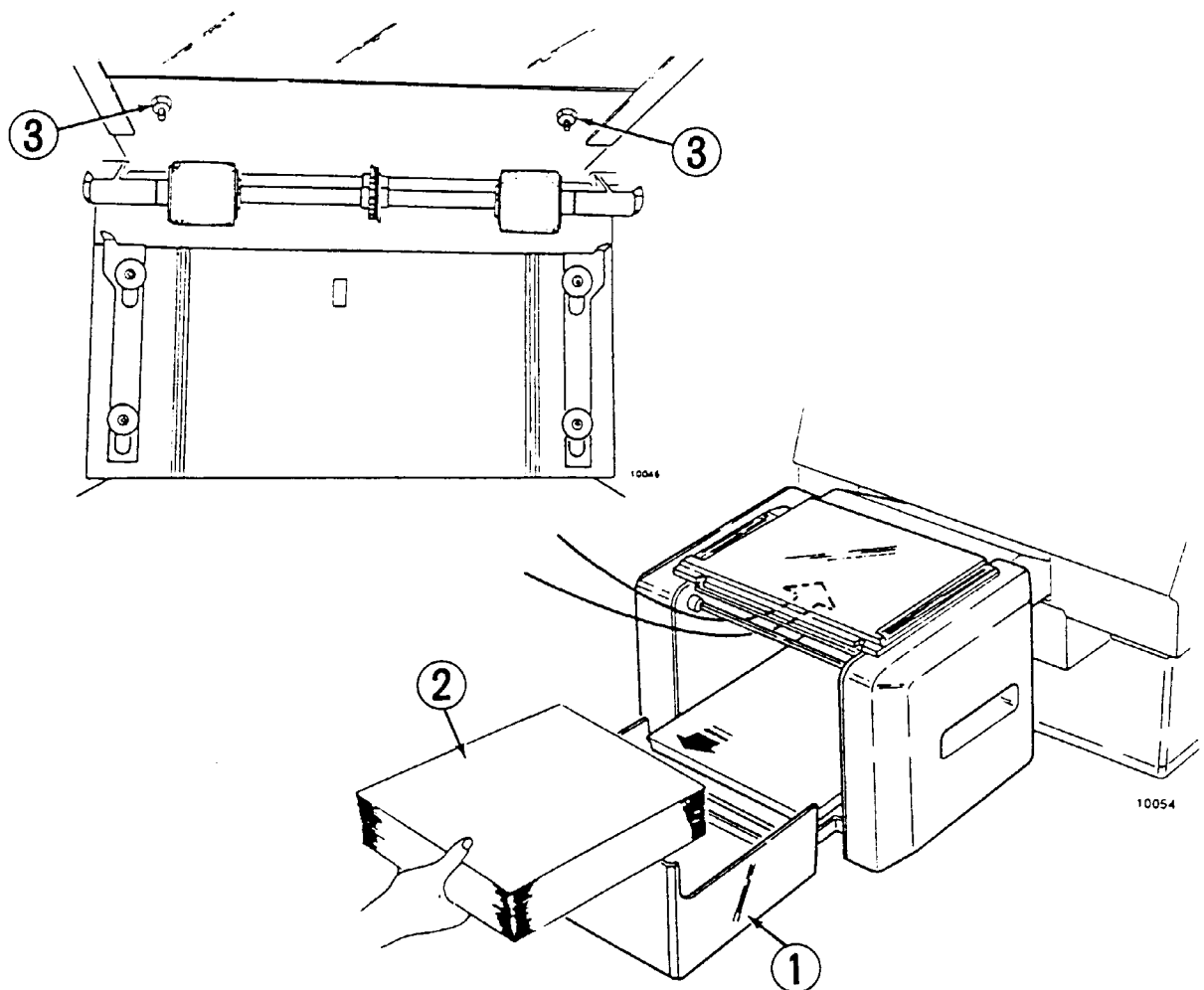

FIGURE 4-3. TOP COVER REMOVAL

#### 4-2-4. Electronics Assembly

##### Removal Procedure:

1. Remove Feeder from Printer.
2. Raise paper elevator (See Figure 4-4).
3. Remove 1 screw shown as "3" in Figure 4-4.
4. Remove 2 screws that secure electronics assembly to front bezel.
5. Pull electronics assembly from rear of Feeder.

##### CAUTION

Be careful not to damage any of the cables as you slide electronics out. You may have to partially pull electronics out and free wire bundles from inside of left and right side frames.

6. Disconnect the:
  - a. elevator motor cable from J1
  - b. paper feed motor cable from J2
  - c. switch harness cable from J3
  - d. optical sensor cable from J6

The electronics assembly is now free for replacement.

##### Replacement Procedure:

Same as above in reverse order.

##### CAUTION

1. Be sure electronics assembly is rated for same voltage as original assembly;
2. Be sure configuration wires (W1 to W3) are properly set for the Printer;
3. On Units with rear-mounted grounding stud, be sure AC and ground wires are up, away from the circuit board.

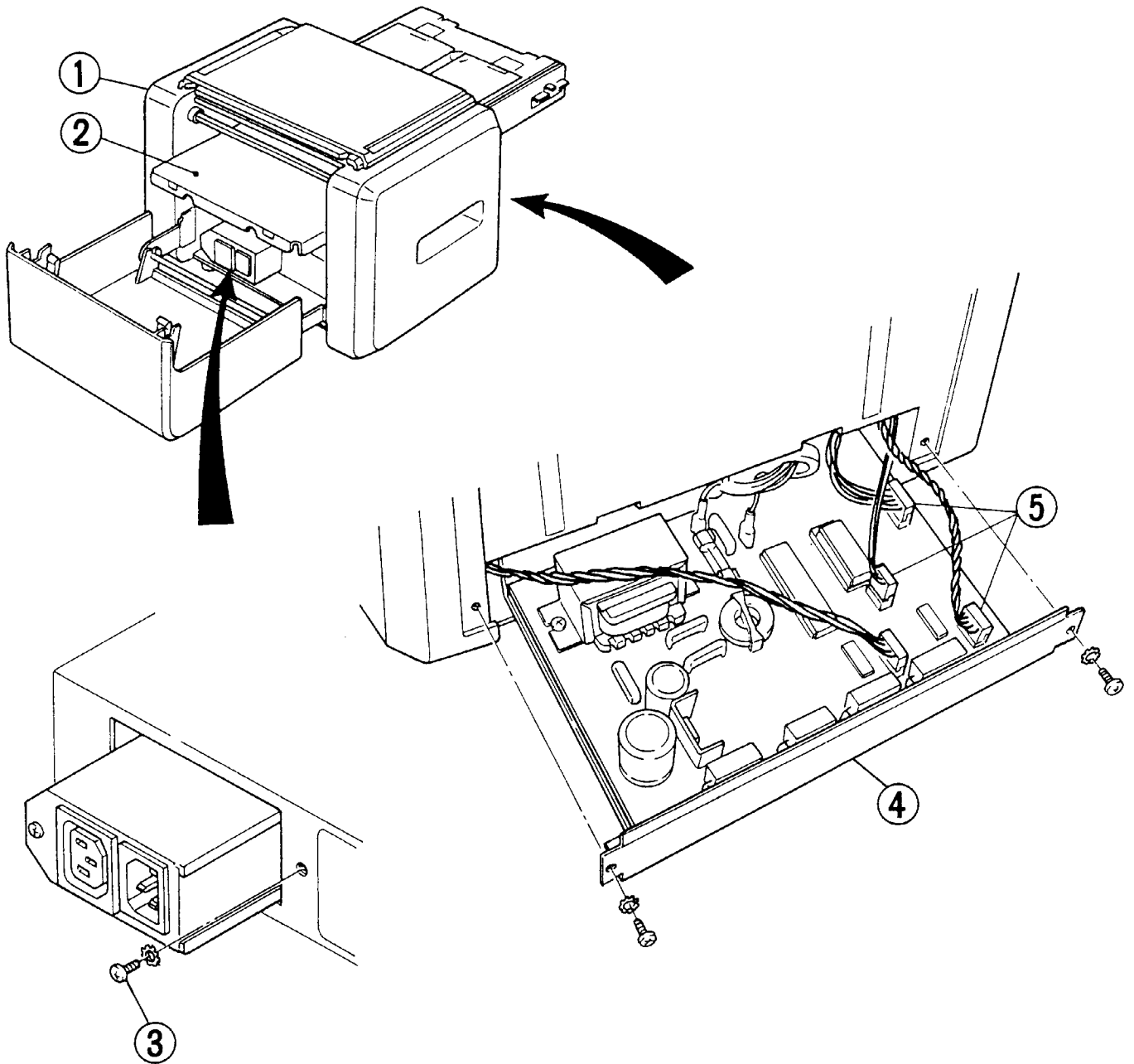

FIGURE 4-4. ELECTRONICS ASSEMBLY REMOVAL

#### 4-2-5. Circuit Board

##### Removal Procedure:

1. Perform Electronics Assembly removal.
2. Disconnect AC input terminals from connectors J4 and J5 (see Figure 4-5).
3. Disconnect AC ground wires from grounding stud.
4. Remove screws that secure transformer to standoffs.
5. Remove screws that secure circuit board, and remove circuit board.

##### Replacement Procedure:

Same as above in reverse order.

##### CAUTION

1. Be sure electronics assembly is rated for same voltage as original assembly;
2. Be sure configuration wires (W1 to W3) are properly set for the Printer;
3. On units with rear-mounted grounding stud, be sure AC and ground wires are up, away from the circuit board.

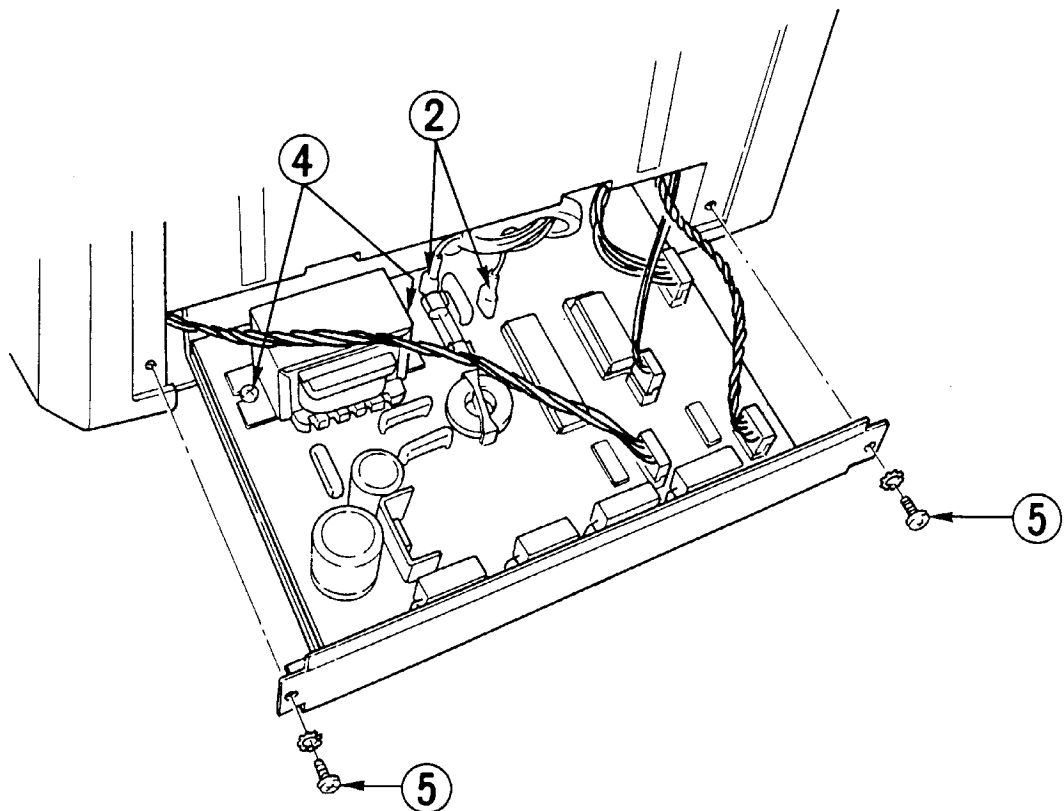

FIGURE 4-5. CIRCUIT BOARD REMOVAL

#### 4-2-6. Fuse

##### Removal Procedure:

1. Perform Electronics Assembly removal, but do not remove cables.
2. Remove fuse from circuit board (see Figure 4-6).

##### Replacement Procedure:

Same as above in reverse order.

##### CAUTION

1. Be sure to replace fuse with one of same value: 1.0 Amp, 250V for 115 VAC or 0.5 Amp, 250V for 230 VAC;
2. On units with rear-mounted grounding stud, be sure AC and grounding wires are up, away from the circuit board.

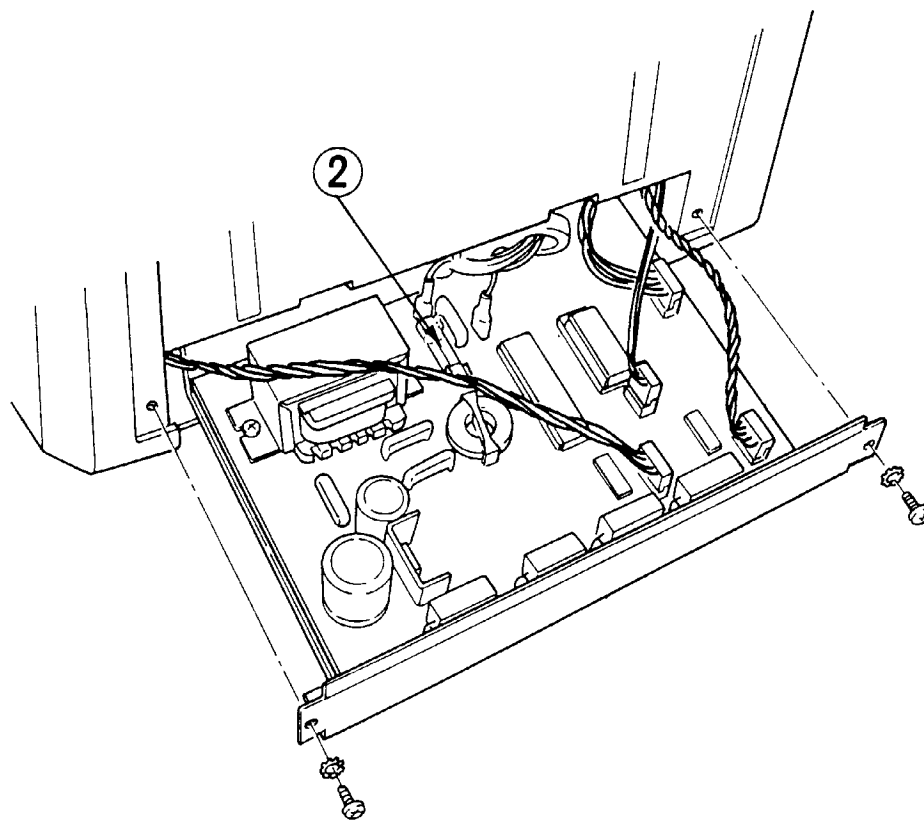

FIGURE 4-6. FUSE REPLACEMENT

## 4-2-7. Elevator Motor

### Removal Procedure:

1. Perform Electronics Assembly removal, but do not disconnect cables.
2. Remove elevator motor cable from circuit board connector J1 (see Figure 4-7).
3. Remove right side cover.
4. Remove 2 screws that secure elevator motor to side frame.
5. Route cable connector through side frame and remove motor.

### Replacement Procedure:

Same as above in reverse order. Check gear mesh for minimal backlash and high spots; adjust motor as necessary.

#### CAUTION

On units with rear-mounted grounding stud, be sure AC and ground wires are up, away from the circuit board.

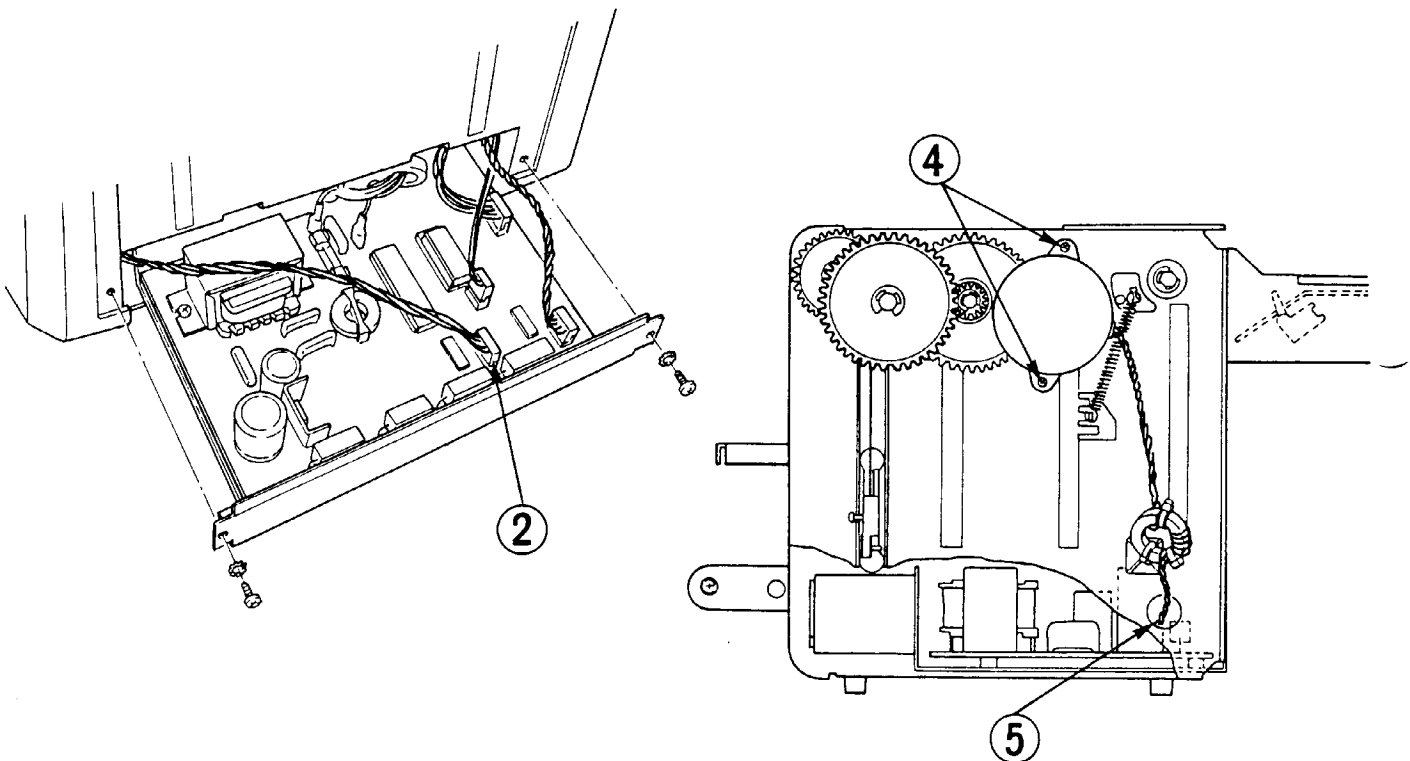

FIGURE 4-7. ELEVATOR MOTOR REMOVAL

#### 4-2-8. Paper Feed Motor

##### Removal Procedure:

1. Perform Electronics Assembly removal, but do not disconnect cables.
2. Remove paper feed motor cable from circuit board connector J2 (see Figure 4-8).
3. Remove left side cover.
4. Route motor cable through side frame and free motor cable from cable clamp on side frame.
5. Remove 2 screws that secure paper feed motor to side frame, and remove motor.

##### Replacement Procedure:

Same as above in reverse order. Check gear mesh for minimal backlash and high spots; adjust motor as necessary.

##### CAUTION

On units with rear-mounted grounding stud, be sure AC and ground wires are up, away from the circuit board.

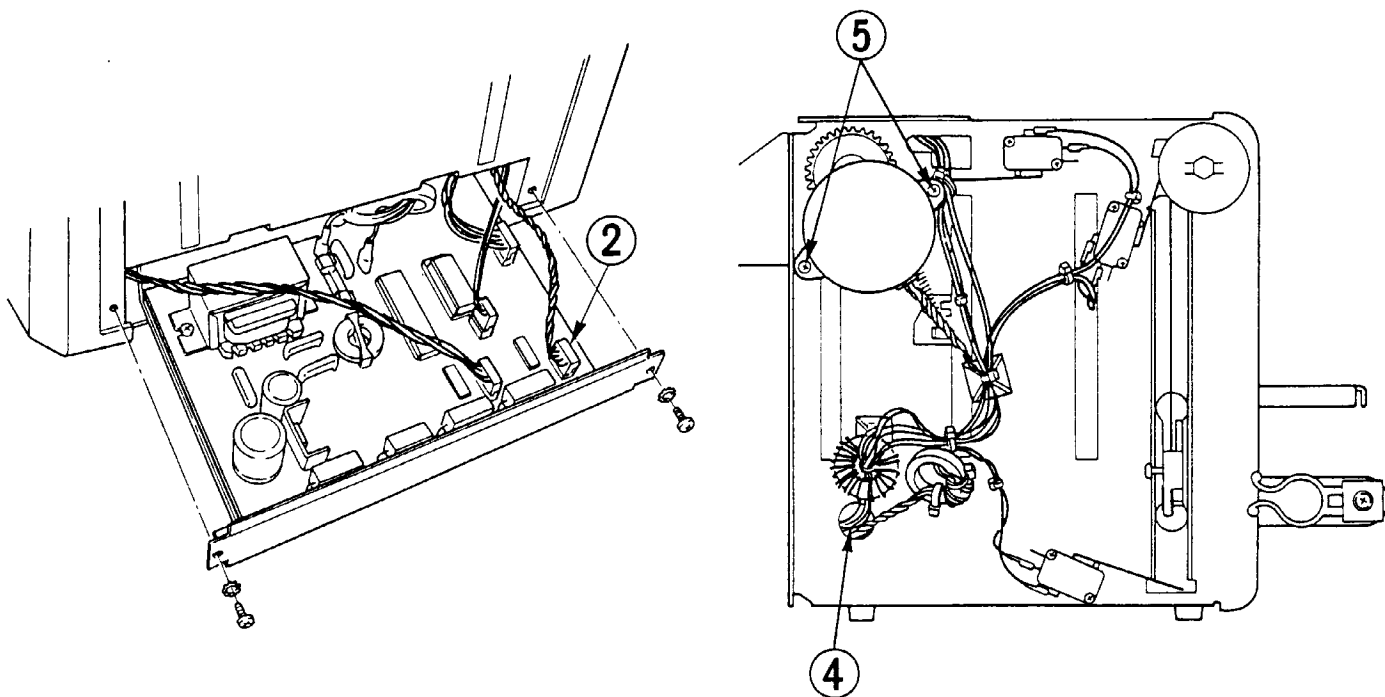

FIGURE 4-8. PAPER FEED MOTOR REMOVAL



#### 4-2-9. Left Side Switches

This section applies to the Elevator Up, Elevator Down, and Paper Cover Switches.

##### Removal Procedure:

1. Remove Feeder from Printer.
2. Remove left side cover.
3. Remove the appropriate switch (see Figure 4-9) as follows:
  - a. disconnect the cable leads from the switch.
  - b. remove screws that secure the switch.

##### NOTE

Paper Cover switch screws can be accessed from inside of frame.

##### Replacement Procedure:

Same as above in reverse order.

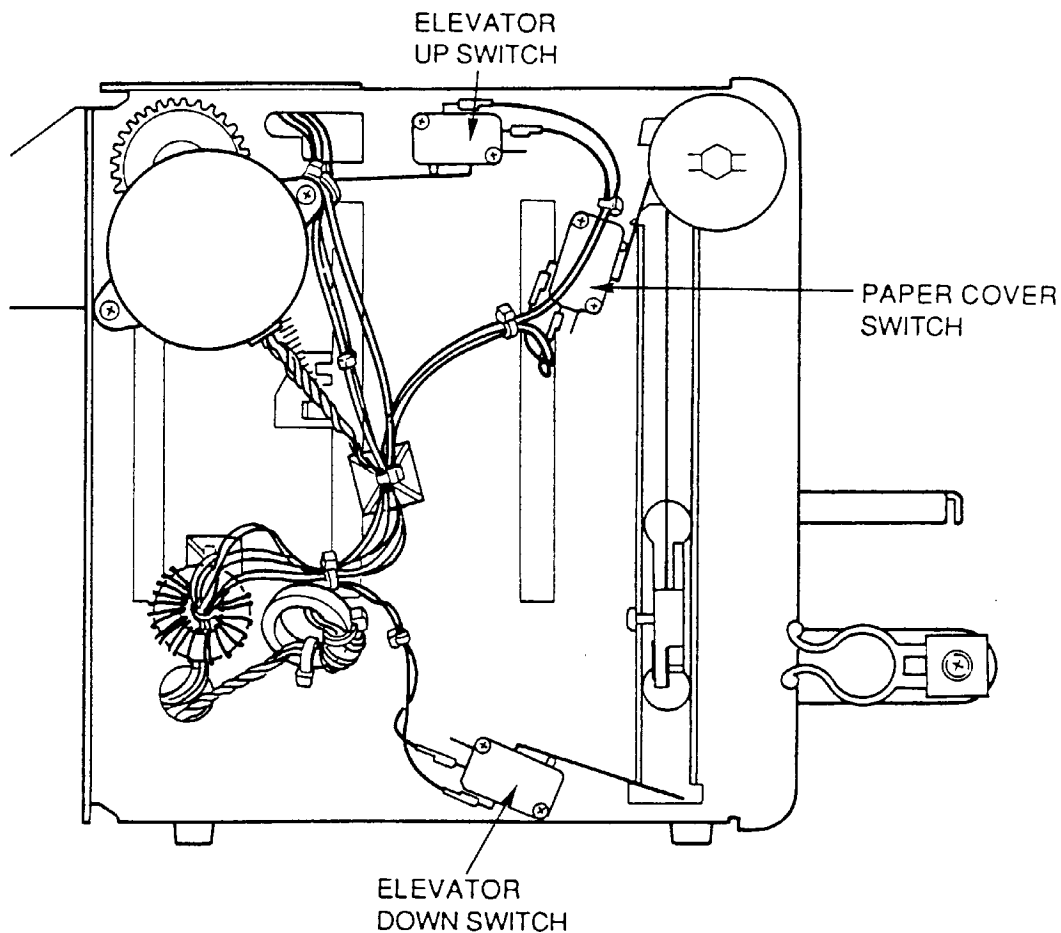

FIGURE 4-9. LEFT SIDE SWITCHES REMOVAL

#### 4-2-10. Paper Path Sensor

##### Removal Procedure:

Disconnect power before proceeding.

1. Remove Feeder from Printer.
2. Remove top cover.
3. Remove 6 screws that secure top plate to frame.
4. Lift top plate and remove sensor from top plate.

##### Replacement Procedure:

Same as above in reverse order.

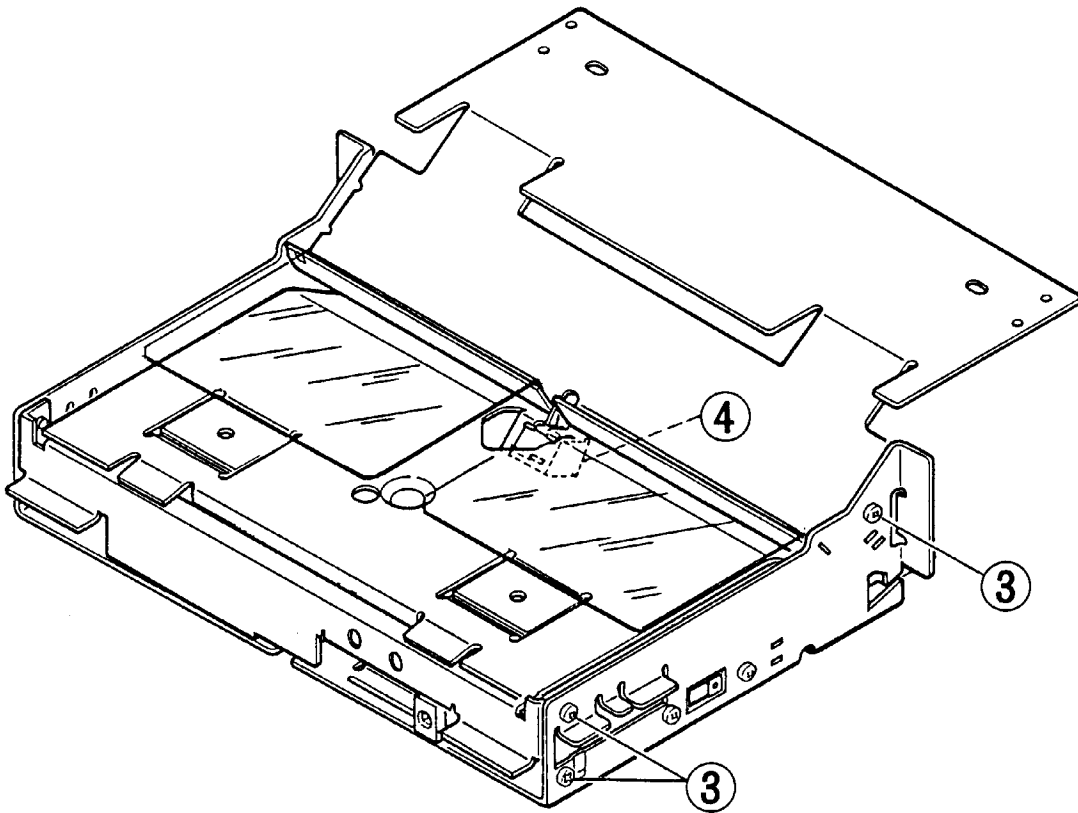

FIGURE 4-10. PAPER PATH SENSER REMOVAL

## 4-2-11. Paper Roller Drive Shaft

### Removal Procedure:

1. Remove Feeder from Printer.
2. Remove both side covers.
3. Remove both E-rings from insides of rollers (see Figure 4-11).

### CAUTION

Do not damage (scratch) shaft.

4. Free drive belt from feed shaft pulley.
5. Slide rollers toward middle of shaft; then, slide shaft left to free it from one pivot arm and right to free it from second pivot arm.
6. Slide shaft from unit.
7. Slide rollers from shaft.

### Replacement Procedure:

Same as above in reverse order.

### NOTE

Be sure to fit drive belt to shaft before assembly, and be sure to orient rollers such that flanges of rollers are facing outside (toward side frames). Rotate shaft by hand to be sure that rollers will feed paper forward. Also check that pressure springs remain attached to pivot arms and side frames.

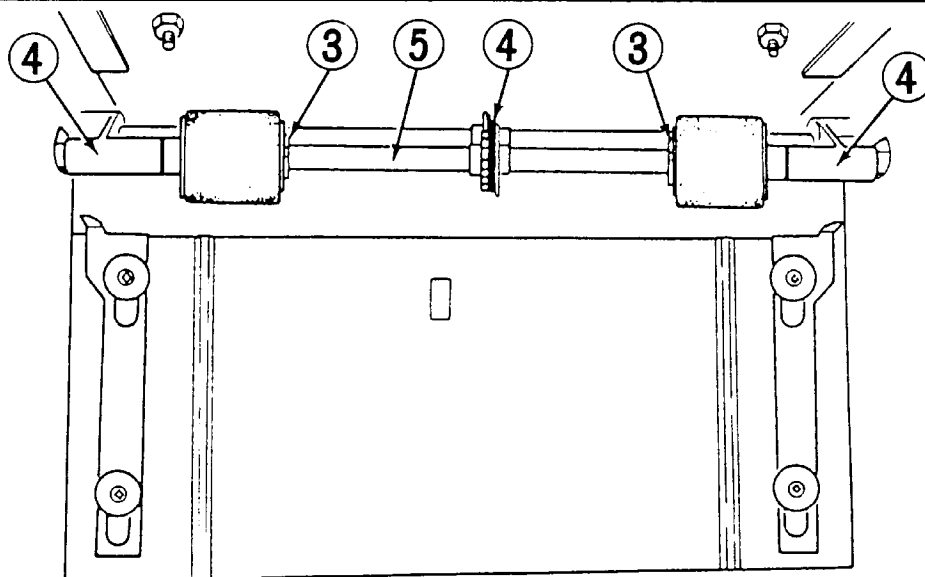

FIGURE 4-11. PAPER ROLLER DRIVE SHAFT REMOVAL

## 4-3. ADJUSTMENT

### 4-3-1. Corner Stripper Adjustment

The corner strippers provide sheet separation during the feed process. If strippers are set too loosely, sheets may skew during feeding or several sheets may feed at once. If the strippers are set too tightly, sheets may not reliably feed.

To properly position the corner strippers, refer to Figure 4-12 and proceed as follows:

1. Open the paper cover.
2. Remove top cover.
3. Remove 6 screws that secure top plate to frame, and turn over top plate.

#### CAUTION

Do not damage the plastic deflectors on the top plate.

4. Check the coverage of the corner strippers on the corners of the paper stack. The corner strippers should each cover 0.1" - 0.12" (2.5 - 3.0 mm) of paper. If sheets have been skewing and the corner stripper(s) are marginally covering the paper, the corner stripper(s) must be moved toward the center. If sheets frequently misfeed during the stripping process, and the corner strippers are covering too much of paper, the corner stripper(s) must be moved toward the side frames.
5. After determining the necessary adjustment, remove the paper stack.
6. Slightly loosen the corner stripper screws, and slide the corner strippers toward or away from the center as necessary. Tighten the screws. Check that the corner strippers move up and down freely.
7. Secure top plate and replace top cover.
8. Load paper and re-test operation.

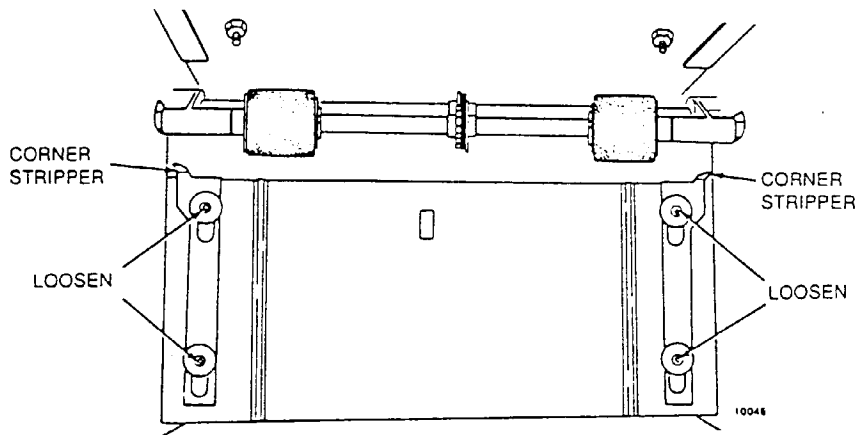

FIGURE 4-12. CORNER STRIPPER ADJUSTMENT

### 4-3-2. Elevator Drive Belt Adjustment

Belts on either side of the paper elevator are driven by a shaft/pulley arrangement at the top of the mechanism to raise/lower the paper elevator. If the belts are set differently, the elevator may not raise/lower evenly and the paper stack may not contact the feeding/stripping mechanism evenly. This may result in paper skewing. A screw on each belt provides for adjustment.

To adjust the belts such that the elevator is level, refer to Figure 4-13 and proceed as follows:

1. Determine the side of the elevator that is too high (or too low).
2. Remove the Feeder from the Printer.
3. Remove the left and right side covers.
4. Locate the tensioning screws on the elevator drive belts and:
  - a. loosen the screw on the side of the elevator that is higher, and/or
  - b. tighten the screw on the side of the elevator that is lower.
5. Replace the side covers, install the Feeder and re-test operation.

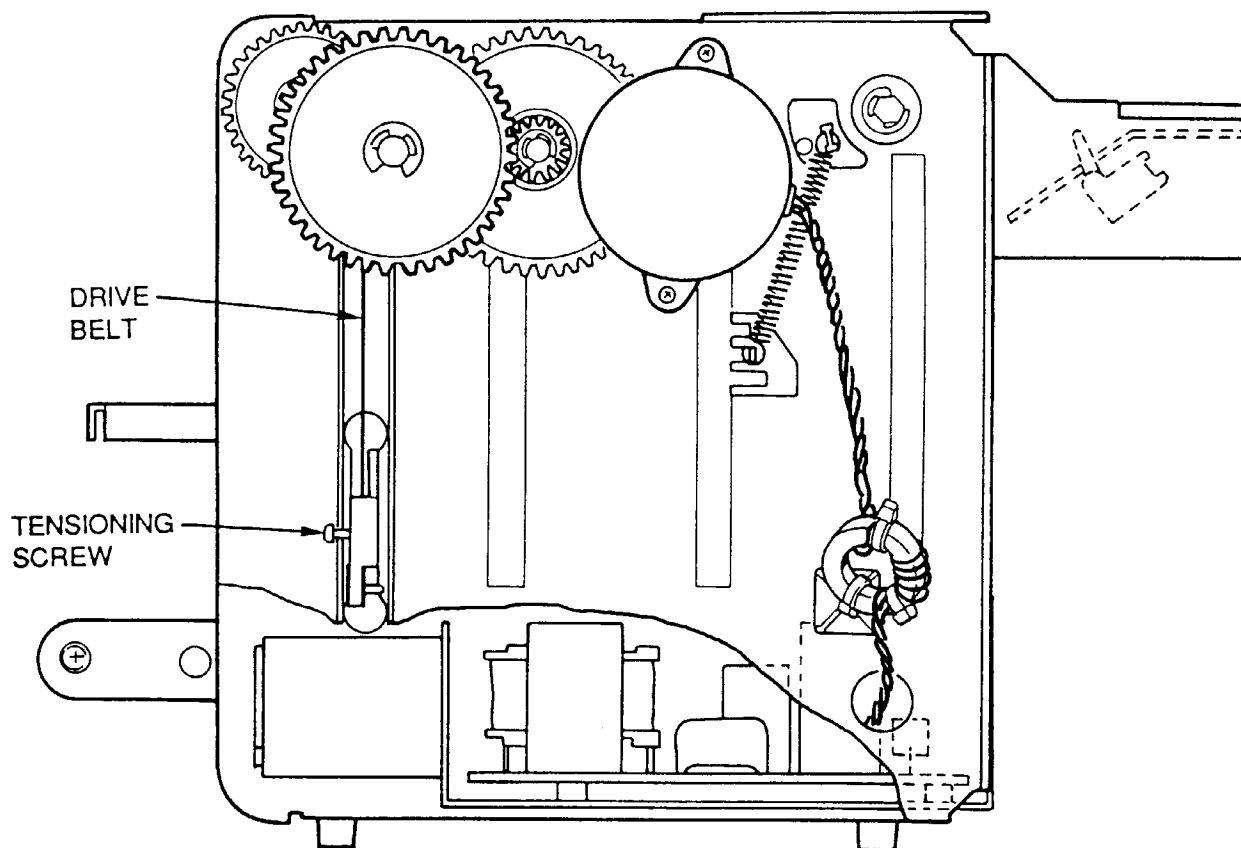

FIGURE 4-13. ELEVATOR DRIVE BELT ADJUSTMENT

### 4-3-3. Drive Roller Shaft Spring Adjustment

A spring on each side of the drive roller shaft maintains pressure between the drive rollers and paper stack. There are three positions on each side frame to locate the spring. The center position is normally used. Excessive spring tension can cause multiple-feeds or cause the Printer to have difficulties pulling the sheet from the Feeder. Light spring tension may cause the feed rollers to slip. Uneven tension – left side different from right – may cause excessive skewing.

To adjust the drive roller shaft springs, refer to Figure 4-14 and proceed as follows:

1. Remove the Feeder from the Printer.
2. Remove the left and right side covers.
3. Locate the spring locating points and:
  - a. if more pressure is needed, relocate the spring to the lower position;
  - b. if less pressure is needed, relocate the spring to the higher position.
4. Replace the side covers, install the Feeder, and re-test operation.

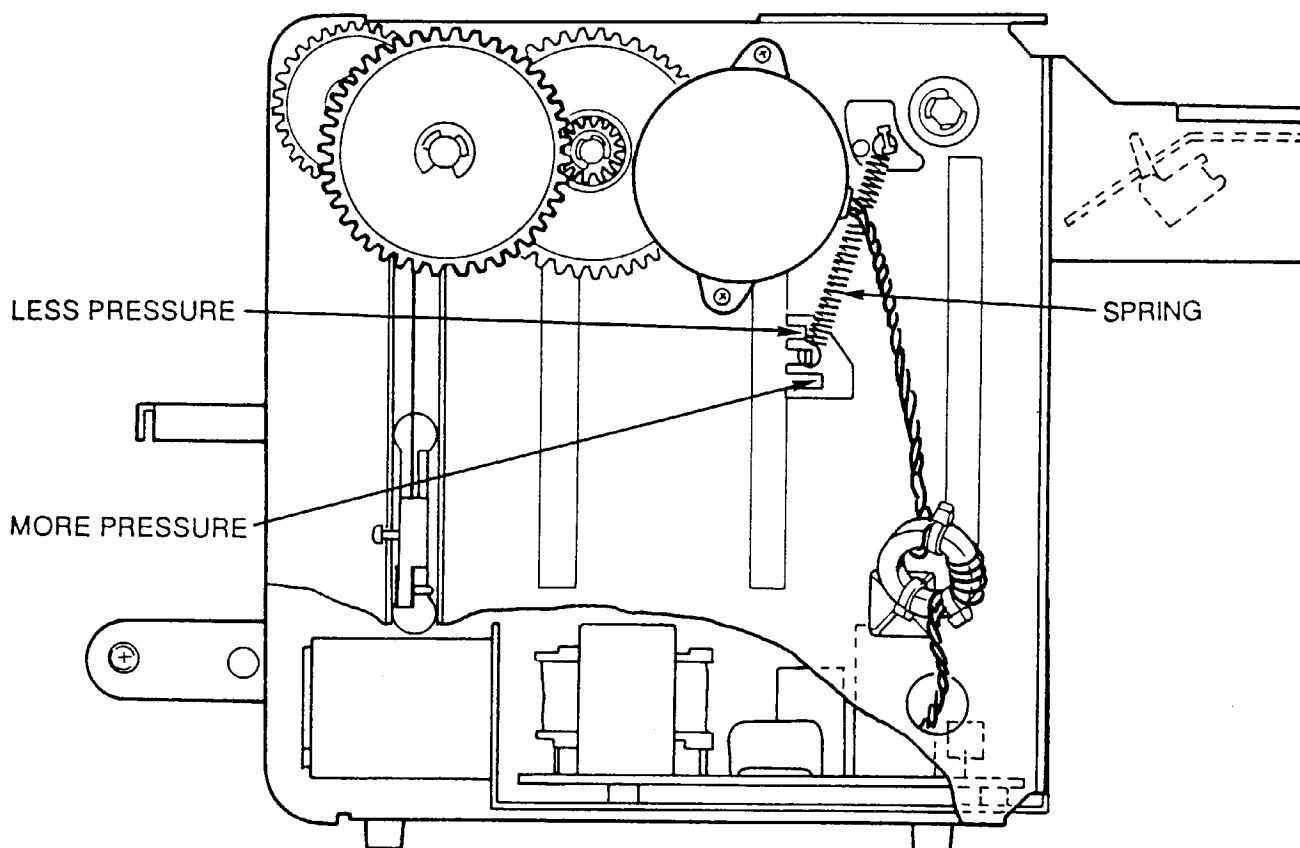

FIGURE 4-14. DRIVE ROLLER SHAFT SPRING ADJUSTMENT

**CHAPTER  
5  
TROUBLESHOOTING**

---

**TABLE OF CONTENTS**

<b>Section</b>	<b>Title</b>	<b>Page</b>
5-1	INTRODUCTION .....	5-1
5-2	ON-SITE TROUBLESHOOTING .....	5-2
5-3	DEPOT LEVEL TROUBLESHOOTING .....	5-4

## 5-1. INTRODUCTION

Troubleshooting is divided into two parts: on-site troubleshooting and depot level troubleshooting. Depot level troubleshooting pertains only to the electronic assembly components. Refer to Chapter 4 for assembly removal and replacement procedures.

Before beginning detailed troubleshooting, check the installation and general operation of the system:

- Be sure that the power connection are properly made.
- If the Printer frequently signals jams, check that the Feeder is fully inserted into the Printer. Check the Printer operation with the standard Printer paper cassette to ensure the Printer is not malfunctioning.
- Open the Feeder's paper cover, remove the sheet from the cassette simulator section, and close the paper cover. Observe the actions of the Feeder as the elevator raises and the first sheet loads.
- Prior to beginning detailed electronic troubleshooting, on the circuit board check:
  1. That the proper jumper wires are in/out as required for the Printer
  2. For proper operating voltages as follows: with a voltmeter, check for +36 VDC,  $\pm 4$  VDC (Feeder idling) at R5. This unregulated voltage should be +31 VDC,  $\pm 3$  VDC when the Feeder is feeding paper. Check for +5 VDC at W18.
- Check the motor cables with an ohm meter to verify motor operation. The resistance between pins 3 and 4, or 5 and 6 should be 82 ohms  $\pm 8$ ; between 5 or 6 and 1, or between 3 or 4 and 2 the resistance should be 41 ohms ( $\pm 4$ ).



## 5-2. ON-SITE TROUBLESHOOTING

TABLE 5-1. ON-SITE TROUBLESHOOTING

Symptom	Probable Cause	Remedy
Elevator does not raise/lower.	<ol style="list-style-type: none"> <li>1. Paper cover switch defective.</li> <li>2. Paper cover switch cable defective.</li> <li>3. Elevator motor defective.</li> <li>4. Defective fuse.</li> <li>5. Electronics assembly defective.</li> </ol>	<ol style="list-style-type: none"> <li>1. Check/Replace paper cover switch.</li> <li>2. Check/Replace paper cover switch cable.</li> <li>3. Check/Replace elevator motor.</li> <li>4. Check/Replace fuse.</li> <li>5. Replace electronics assembly.</li> </ol>
Elevator motor stays on.	<ol style="list-style-type: none"> <li>1. Elevator up switch defective.</li> <li>2. Elevator up switch cable defective.</li> <li>3. Elevator down switch defective.</li> <li>4. Elevator down switch cable defective.</li> <li>5. Electronics assembly defective.</li> </ol>	<ol style="list-style-type: none"> <li>1. Check/Replace elevator up switch.</li> <li>2. Check/Replace elevator up switch cable.</li> <li>3. Check/Replace elevator down switch.</li> <li>4. Check/Replace elevator down switch cable.</li> <li>5. Replace electronics assembly.</li> </ol>
Elevator does not raise properly.	<ol style="list-style-type: none"> <li>1. Side guides misaligned.</li> <li>2. Elevator up switch defective.</li> <li>3. Elevator motor defective.</li> </ol>	<ol style="list-style-type: none"> <li>1. Check/Adjust paper side guides.</li> <li>2. Check/Replace elevator up switch.</li> <li>3. Replace elevator motor.</li> </ol>
Paper feed rollers do not activate.	<ol style="list-style-type: none"> <li>1. Paper present sensor defective.</li> <li>2. Paper feed motor defective.</li> <li>3. Electronics assembly defective.</li> </ol>	<ol style="list-style-type: none"> <li>1. Check/Replace paper present sensor.</li> <li>2. Check/Replace paper feed motor.</li> <li>3. Replace electronics assembly.</li> </ol>
Paper does not feed up to Printer feed roller.	<ol style="list-style-type: none"> <li>1. Paper present sensor defective.</li> <li>2. Paper present sensor cable defective.</li> <li>3. Electronics assembly defective.</li> </ol>	<ol style="list-style-type: none"> <li>1. Check/Replace paper present sensor.</li> <li>2. Check/Replace paper present sensor cable.</li> <li>3. Replace electronics assembly.</li> </ol>

TABLE 5-2. ON-SITE TROUBLESHOOTING (Cont'd)

Symptom	Probable Cause	Remedy
Paper misfeeds – rollers slip.	<ol style="list-style-type: none"> <li>1. Paper drive rollers smooth – initial usage.</li> <li>2. Paper drive rollers dirty – unit has been operating.</li> <li>3. Elevator up switch defective.</li> <li>4. Corner strippers adjusted too tightly.</li> <li>5. Drive shaft springs improperly set.</li> <li>6. Paper drive rollers defective.</li> </ol>	<ol style="list-style-type: none"> <li>1. Clean paper drive rollers with standard platen cleaning agent (not alcohol).*</li> <li>2. Clean paper drive rollers with damp, lint-free cloth.</li> <li>3. Check/Replace elevator up switch.</li> <li>4. Adjust corner strippers.</li> <li>5. Relocate drive shaft springs.</li> <li>6. Replace paper drive roller shaft.</li> </ol>
Paper skews.	<ol style="list-style-type: none"> <li>1. Corner stripper adjusted too loosely.</li> <li>2. Paper drive rollers dirty.</li> <li>3. Elevator drive belts set differently.</li> <li>4. Drive shaft springs improperly set.</li> </ol>	<ol style="list-style-type: none"> <li>1. Adjust corner strippers.</li> <li>2. Clean paper drive roller with damp, lint-free cloth.</li> <li>3. Adjust elevator belt tensioning screw.</li> <li>4. Relocate drive shaft springs.</li> </ol>

\* When Feeders are first installed, the feeder rollers should be cleaned once with a standard platen cleaning agent to remove any residue that may have developed in the manufacturing process. If you gently scrape the roller with your fingernail and a white, powdery residue appears, then the rollers need to be cleaned with a platen cleaning agent. During normal operation, occasional cleaning with a damp, lint free cloth may be required to remove paper dust. DO NOT USE THE PLATEN CLEANING AGENT FOR ROUTINE MAINTENANCE.

## 5-2. DEPOT LEVEL TROUBLESHOOTING

TABLE 5-2. DEPOT LEVEL TROUBLESHOOTING

Symptom	Probable Cause	Remedy
Elevator does not raise or lower.	<ol style="list-style-type: none"> <li>1. Cover open switch circuit not functional.</li> <li>2. No or low DC voltage to Elevator Motor.</li> <li>3. Defective IC1.</li> <li>4. Defective IC3.</li> </ol>	<ol style="list-style-type: none"> <li>1. Check COVDN/ line from J3-5 thru R9, R10 and C8 back to IC3-10.</li> <li>2. Check unregulated +34 VDC circuit or main fuse.</li> <li>3. Replace IC1.</li> <li>4. Replace IC3.</li> </ol>
Elevator raises, but does not stop - grinding noise.	<ol style="list-style-type: none"> <li>1. Elevator up switch not functional.</li> <li>2. Defective Port on IC3.</li> </ol>	<ol style="list-style-type: none"> <li>1. Check ELUP/ line from J3-8 thru R6, R13 and C5 back to IC3-13.</li> <li>2. Replace IC3.</li> </ol>
Elevator lowers, but does not stop - grinding noise.	<ol style="list-style-type: none"> <li>1. Elevator down switch circuit not functional.</li> <li>2. Defective Port on IC3.</li> </ol>	<ol style="list-style-type: none"> <li>1. Check ELDN/ line from J3-7 thru R7, R2 and C6 back to IC3-13.</li> <li>2. Replace IC3.</li> </ol>
All AC and DC voltages present, but Feeder not operational.	<ol style="list-style-type: none"> <li>1. Defective IC3, IC4, IC5.</li> <li>2. MCU crystal circuit defective.</li> </ol>	<ol style="list-style-type: none"> <li>1. Isolate and replace defective component(s).</li> <li>2. Check C9, C10 and crystal.</li> </ol>
Paper Feed Motor does not activate.	<ol style="list-style-type: none"> <li>1. Paper present sensor circuit not functional.</li> <li>2. No or low DC voltage to Paper Feed Motor.</li> <li>3. Defective IC2.</li> <li>4. Defective IC3.</li> </ol>	<ol style="list-style-type: none"> <li>1. Check OPT PRES/ line from J6-4 thru R26, back to IC3-14; also check +5 VDC at R27.</li> <li>2. Check unregulated +34 VDC circuit or main fuse.</li> <li>3. Replace IC2.</li> <li>4. Replace IC3.</li> </ol>
Paper does not feed to end of cassette simulator.	<ol style="list-style-type: none"> <li>1. Paper present sensor circuit not functional.</li> </ol>	<ol style="list-style-type: none"> <li>1. Check OPT PRES/ line from J6-4 thru R26, back to IC3-14; also check +5 VDC at R27.</li> </ol>
Gap between paper feeds is too large or too small.	<ol style="list-style-type: none"> <li>1. Feeder incorrectly configured for Printer.</li> </ol>	<ol style="list-style-type: none"> <li>1. Check jumpers W1, W2 and W3 for proper configuration.</li> </ol>
Feeder loads first sheet, but does not continue.	<ol style="list-style-type: none"> <li>1. Paper present sensor not functional.</li> <li>2. Defective Port on IC3.</li> </ol>	<ol style="list-style-type: none"> <li>1. Check OPT PRES/ line from J6-4 thru R26, back to IC3-14; also check +5 VDC at R27.</li> <li>2. Replace IC3.</li> </ol>